



FAGOR AUTOMATION

# Linear encoders

for CNC Machines and High Accuracy Applications





# Linear encoders

Over 35 years of continuous evolution





Fagor Automation has been manufacturing high quality linear encoders using precision optical technology for more than 35 years.

Over the years Fagor has created, developed and patented systems, components and technologies that allow us to offer best quality and features over the complete range of product utilizing innovative production methods.

Hence making Fagor Automation the most efficient alternative in the world of feedback systems.

## Modern facilities and innovative processes

In order to ensure quality and reliability in all its products Fagor Automation utilizes the most advanced technology and testing and manufacturing facilities. From centralized computer control temperature monitoring, cleanliness and relative humidity control, a must for the feedback system manufacturing process, to laboratories for climate, vibration and EMC testing to certify the designs.



## With state-of-the-art technology

Fagor Automation's commitment to this technology and quality is evident by creation of **Aotek** in 2002, a dedicated research center providing various technological breakthroughs. This investment has resulted in large number of patents and customized solutions in electrical, optical and mechanical fields.

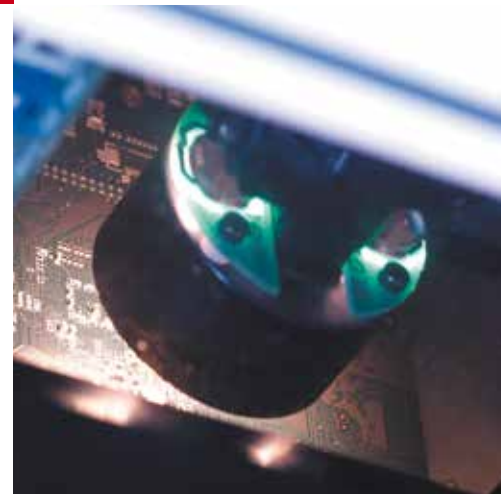

 PATENT PENDING

Steel-tape tensioner



 PATENT PENDING

Fringe scanning

# Superior technology and innovative design

Fagor Automation develops with maximum professionalism the three cornerstones in encoder design: optical design, electronic design and mechanical design that result in a state-of-the-art product.

## Optical design

In the vanguard of measurement technologies, Fagor Automation uses transmission and reflective optics in its range of encoders.

With new scanning techniques, such as the new single-window scanning technology, more immune to contamination, which is critical for operations in extreme conditions, and contributes to attaining high quality signals that minimize interpolation errors, resulting in improved accuracy of the measurement system.

## Electronic design

Fagor Automation uses latest generation integrated electronic components in their design. Owing to that, the optimization of the signals at high traversing speeds is achieved, with micrometric accuracy and nanometric resolution.

## Mechanical design

Fagor Automation designs and manufactures the most innovative and reliable measuring systems using its advanced mechanical designs. These designs using titanium and stainless steel materials provide the encoders with optimum robustness ensuring best performance in machine tool applications.

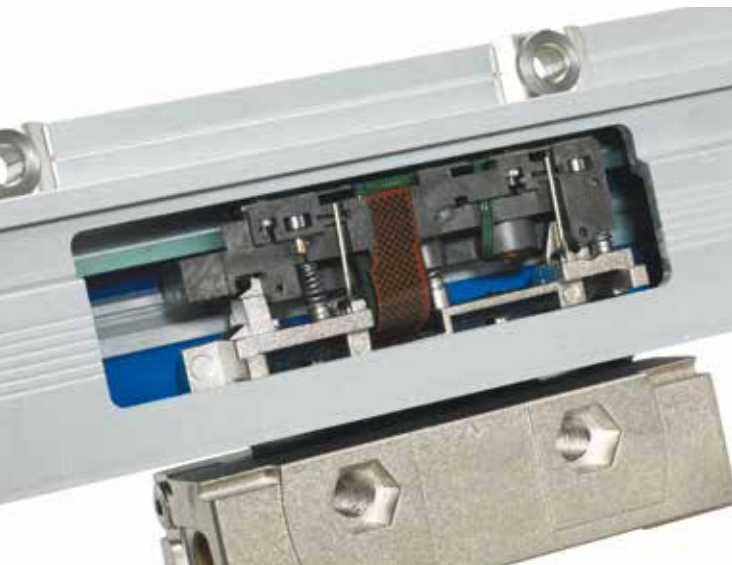
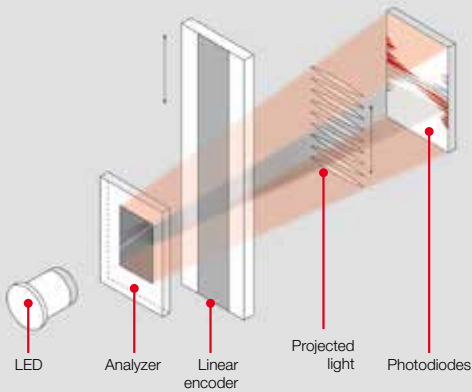

## Thermal performance

When designing the encoders Fagor Automation has taken into account the effect of temperature change on their performance.

Most machine shops do not operate in temperature controlled environment hence affecting the accuracy of finished part. Using the TDMS™ system, **Thermal Determined Mounting System** which controls expansion/contraction, Fagor linear encoders can deliver consistent accuracy and repeatability.

For linear encoders more than three meters long, Fagor guarantees a thermal behavior identical to that of the machine surface it is mounted on thanks to the special mounting system at the end of the linear encoders.

## Enclosed design

The robust aluminum profile encasing the graduated glass provides the primary protection.

The sealing lips provides protection against contaminants and liquids as the reader head travels along the profile. The reader head movement along the graduated glass provides a perfectly balanced system accurately capturing the machine movement. The reader head travels on precision bearing with minimum contact with the profile hence minimizing the friction.

The optional air inlet at both ends of the encoder and at the reader head provides increased protection levels against contaminants and liquids.



The TDMS™ system is only available on G2 and SV2 series linear encoders.

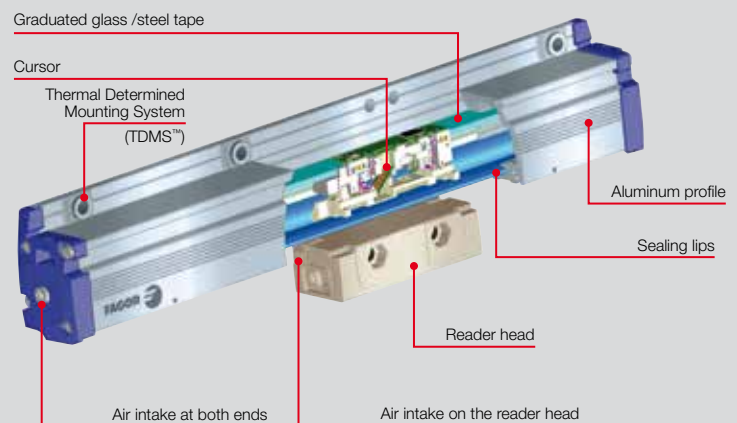

# Quality

## Accuracy certificate

Every single Fagor encoder is subjected to an extensive final accuracy check. This control is carried out on a computerized measuring bench equipped with a laser interferometer located inside a climate controlled chamber at 20°C. The resulting final accuracy graph is supplied with every Fagor encoder.

### The quality of the measurement is mainly determined by:

- Etching quality
- The quality of the scanning process
- The quality of the electronics that processes the signals

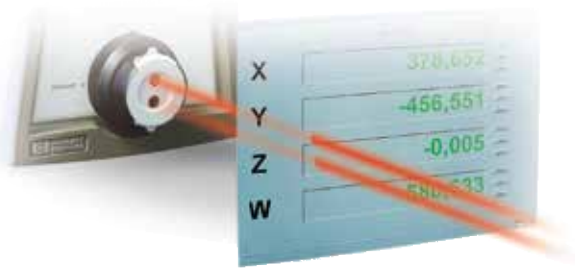
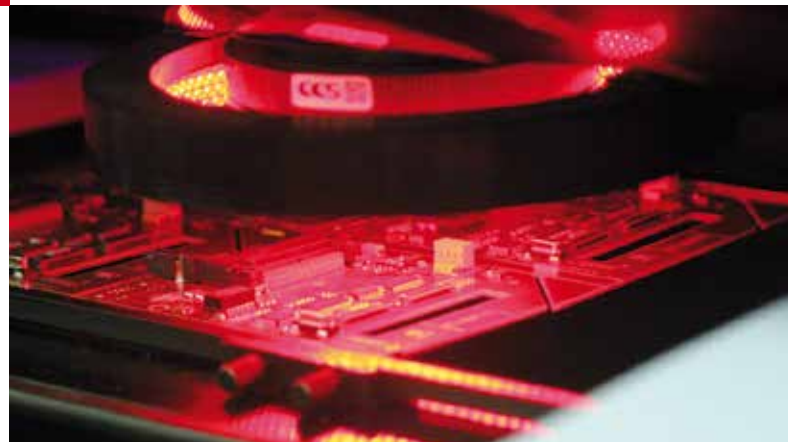

# A

## ABSOLUTE

Technology and range .....	10
Signals .....	12
LA series .....	14
G2A series .....	16
S2A series .....	18
SV2A series .....	20
Cables and extension cables .....	22

# I

## INCREMENTAL

Technology and range .....	26
Signals .....	28
L series .....	30
G2 series .....	32
S2 series .....	34
SV2 series .....	36
Cables and extension cables .....	38
Accessories .....	42



# Range

**Analyze the application to make sure that the proper encoder will be selected for the machine.**

To do this, bear in mind the following considerations:

**Installation:** Consider the physical length of the installation and the space available for it. These aspects are crucial to determine the type of linear encoder to use (type of profile).

**Accuracy:** Each linear encoder comes with a graph showing its accuracy along its measuring length.

**Signal:** The signal selection considers the communication protocols compatible with the main CNC manufacturers.

**Resolution:** The resolution of the control of machine-tools depends on the linear encoder.

**Cable length:** The length of the cable depends on the type of signal.

**Compatibility:** The signal must be compatible with the control system.

**Speed:** The speed requirements for the application must be analyzed before choosing the linear encoder.

**Shock and Vibration:** Fagor linear encoders withstand vibrations of up to 200 m/s<sup>2</sup> and shocks of up to 300 m/s<sup>2</sup>.

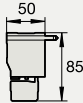
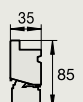
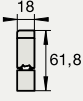
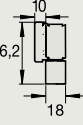
Series	Section	Measuring lengths
LA Long		440 mm to 50 m
G2A Wide		140 mm to 3 040 mm
S2A Reduced		70 mm to 1 240 mm
SV2A Reduced		70 mm to 2 040 mm



# Technology

**The absolute measurement system is a direct digital measure of machine position. It is fast, accurate and does not require homing of the machine. The position value is available from the moment the machine is turned on and may be requested by the connected device (CNC) at any time.**

The absolute encoders provide direct measure of machine position without using any intermediate device. The positioning errors originating from machine mechanics are minimized as the encoder is directly mounted to the machine surface and the guide ways. The encoder sends the real machine movement data to the CNC and mechanical errors caused due to thermal behavior of the machine, pitch error compensation and backlash etc. are minimized.

Both measuring methods have two different etchings:

- **Incremental graduation:** Used to generate incremental signals that are counted inside the reader head. The incremental graduation also provides the 1 Vpp analog signals except in systems that only use digital signals.
- **Absolute graduation:** It is a unique binary code which is imprinted along the measuring length of encoder.

Fagor encoders calculate the absolute position by reading the unique binary code using a high precision optical sensor.

Graduated glass encoder

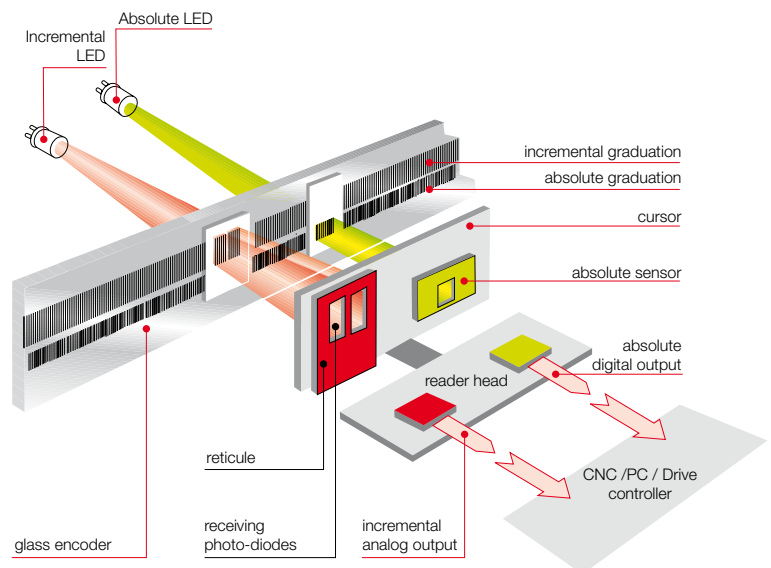

Accuracy	Signals	Pitch Resolution up to	Model	Page
± 5 µm	SSI + 1 Vpp FAGOR	0.1 µm	LA	14
	SSI + 1 Vpp SIEMENS®(*)	1 µm	LAS	
	FANUC® / MITSUBISHI® / PANASONIC® / FAGOR	0.01 µm	LAF / LAM / LAP / LAD	
	SIEMENS®(*)		LAD + EC-PA-DQ1	
	BiSS®		LAB	
± 5 µm and ± 3 µm	SSI + 1 Vpp FAGOR / SIEMENS®(*)	0.1 µm	G2A / G2AS	16
	FANUC® / MITSUBISHI® / PANASONIC® / FAGOR	0.01 µm	G2AF / G2AM / G2AP / G2AD	
	SIEMENS®(*)		G2AD + EC-PA-DQ1	
	BiSS®		G2AB	
± 5 µm and ± 3 µm	SSI + 1 Vpp FAGOR / SIEMENS®(*)	0.1 µm	S2A / S2AS	18
	FANUC® / MITSUBISHI® / PANASONIC® / FAGOR	0.01 µm	S2AF / S2AM / S2AP / S2AD	
	SIEMENS®(*)		S2AD + EC-PA-DQ1	
	BiSS®		S2AB	
± 5 µm and ± 3 µm	SSI + 1 Vpp FAGOR / SIEMENS®(*)	0.1 µm	SV2A / SV2AS	20
	FANUC® / MITSUBISHI® / PANASONIC® / FAGOR	0.01 µm	SV2AF / SV2AM / SV2AP / SV2AD	
	SIEMENS®(*)		SV2AD + EC-PA-DQ1	
	BiSS®		SV2AB	

(\*) SIEMENS®: valid for family Solution Line.



Graduated steel encoder

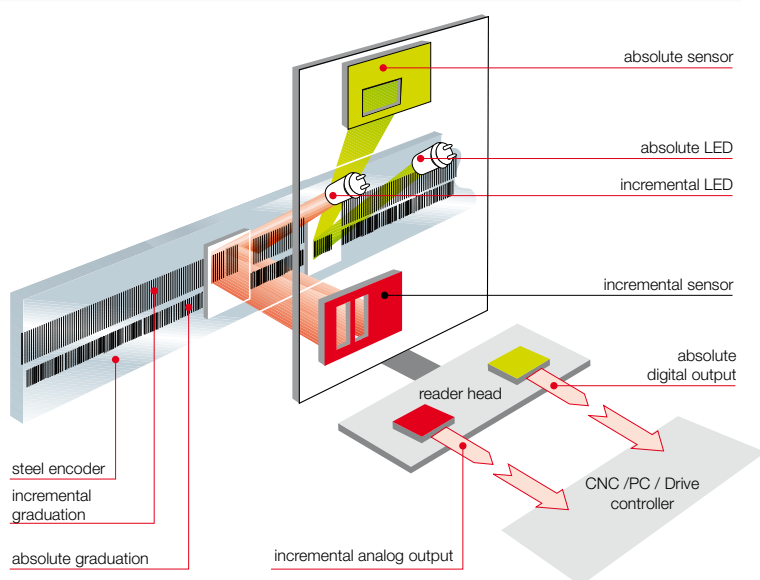

## Linear encoders

Fagor Automation uses two measuring methods in their absolute linear encoders:

- Graduated glass:** Linear encoders with a measuring length of up to 3 040 mm use optical transmission. The light from the LED goes through a graduated glass and a reticule before reaching the receiving photo diodes. The period of the generated electrical signals is the same as the graduation pitch.
- Graduated steel:** Linear encoders with a measuring length over 3 040 mm use the autoimage principle by means of diffuse light reflected on the graduated steel tape. The reading system consists of one LED, as the light source of the linear encoder; a mesh that makes the image and a monolithic photo detector element in the plane of the image specially designed and patented by Fagor Automation.

# Electrical output signals

They are defined according to the communication protocol. Protocols are specific communication languages used by linear encoders to communicate with the machine controller (CNC, drive, PLC, etc.). There are different communication protocols depending on the CNC manufacturer. Fagor Automation offers absolute encoders with different communication protocols compatible with the main CNC manufacturers on the market such as FAGOR, FANUC®, SIEMENS®, MITSUBISHI®, PANASONIC® and others.

## absolute

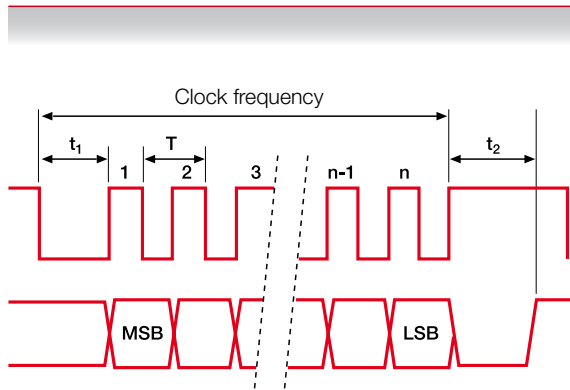

## 1 Vpp differential

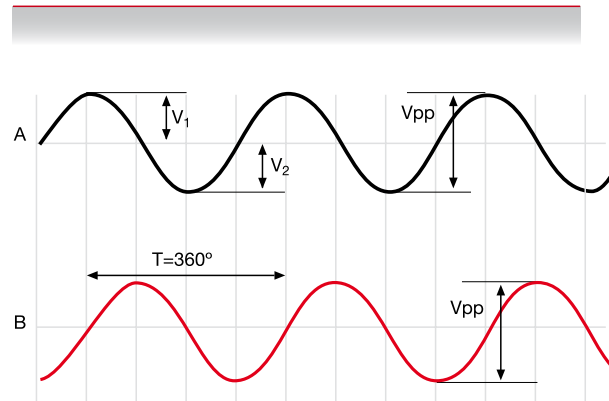

### FAGOR systems

#### Fagor FeeDat® Serial Interface

These systems only use digital signals.

The absolute encoder is connected via the SERCOS board.

A high communication speed of 10 MHz provides a loop time of 10 microseconds. Communication also includes alarms, analog signal values and other encoder parameters.

Fagor FeeDat® is an open communication protocol that is also used to communicate with other CNC system manufacturers.



SERCOS counter board

### SIEMENS® systems

#### DRIVE-CLiQ® Interface

These systems only use digital signals.

The absolute encoder is connected through a cable having the electronics integrated into the connector and it is connected to the "Solution Line" family without the need for intermediate modules.

### Sistemas FANUC®

#### Serial Interface for position feedback encoder

These systems only use digital signals. The absolute encoder is connected through the SDU (Separate Detector Unit) device and is valid for communication protocol versions FANUC® 01, 02 and αi serial interface.

### MITSUBISHI® systems

#### High Speed Serial Interface - HSSI

These systems only use digital signals. The absolute encoder is connected through the MDS Series drive and it is valid for MITSUBISHI® communication protocol versions Mit 03-2/4.

## PANASONIC® systems

### Serial Communication

These systems only use digital signals. These systems only use digital signals. The absolute encoder is connected through the MINAS series drive.

- The systems can be connected to linear motors, rotary motors and DD motors.
- Automatic drive/motor matching software available.
- Vibration, resonance suppression filters available with setting done automatically / manually.
- Drive range from 50 W to 15 kW at AC 100 V / 200 V / 400 V.
- Safety Torque Off feature available.

PANASONIC® systems  
A5 series



## Systems with SSI or BiSS®

The SSI or BiSS® communication interfaces are widely implemented among manufacturers of drive and control systems (FAGOR, SIEMENS®, etc.). These systems and the absolute encoders with SSI or BiSS® interfaces can be connected as long as they are compatible.

### 1. Systems with Serial Synchronous Interface - SSI

These systems synchronize the SSI interface with the sinusoidal 1 Vpp signals. Once the absolute position has been obtained through the SSI interface, the encoders keep operating with incremental 1 Vpp signals.

#### A. FAGOR systems

##### ABSOLUTE signals

Transmission	SSI synchronous serial transfer via RS 485
Levels	EIA RS 485
Clock frequency	100 kHz - 500 kHz
Max. bit (n)	32
$T$	1 $\mu$ s + 10 $\mu$ s
$t_1$	> 1 $\mu$ s
$t_2$	20 $\mu$ s - 35 $\mu$ s
SSI	Binary
Parity	No

##### 1 Vpp DIFFERENTIAL signals

Signals	A, /A, B, /B
$V_{App}$	1 V +20%, -40%
$V_{Bpp}$	1 V +20%, -40%
DC offset	2.5 V $\pm$ 0.5 V
Signal period	20, 40 $\mu$ m
Supply V	5 V $\pm$ 10%
Max. cable length	75 meters
A, B centered: $ V_1 - V_2  / 2 V_{pp}$	< 0.065
A&B relationship $V_{App} / V_{Bpp}$	0.8 $\div$ 1.25
A&B phase shift	90° $\pm$ 10°

#### B. SIEMENS® Systems

The connection of absolute encoders to SIEMENS® systems is made through the SME 25 or SMC 20 modules of the Solution Line family.

##### ABSOLUTE signals

Transmission	SSI synchronous serial transfer via RS 485
Levels	EIA RS 485
Clock frequency	100 kHz - 500 kHz
Max. bit (n)	28
$T$	1 $\mu$ s + 10 $\mu$ s
$t_1$	> 1 $\mu$ s
$t_2$	20 $\mu$ s - 35 $\mu$ s
SSI	Gray
Parity	Yes

##### 1 Vpp DIFFERENTIAL signals

Signals	A, /A, B, /B
$V_{App}$	1 V +20%, -40%
$V_{Bpp}$	1 V +20%, -40%
DC offset	2.5 V $\pm$ 0.5 V
Signal period	20, 40 $\mu$ m
Supply V	5 V $\pm$ 10%
Max. cable length	100 meters
A, B centered: $ V_1 - V_2  / 2 V_{pp}$	< 0.065
A&B relationship $V_{App} / V_{Bpp}$	0.8 $\div$ 1.25
A&B phase shift	90° $\pm$ 10°

#### C. Other systems

Please contact FAGOR for information on compatibility of the encoders with other systems.

### 2. Systems with BiSS® interface

These systems use digital + 1 Vpp sinusoidal signals or only digital signals.

The absolute encoder with BiSS® C BP3 protocol is compatible with BiSS® C Unidirectional.

The absolute encoder is connected to the drive or system with BiSS® C BP3 or BiSS® C unidirectional interface. Please contact FAGOR for information on compatibility of the encoders with these systems.

# LA series



Specially designed for high performance environment requiring speed and accuracy.

Their special mounting system guarantees a thermal behavior identical to that of the machine surface the linear encoder is mounted on. This is achieved through floating fixtures at their ends with the base of the machine and by tensioning the etched steel tape. This system eliminates the errors caused by temperature changes and ensures maximum accuracy and repeatability of the linear encoders.

The steel tape graduation pitch is 40 µm. Measuring lengths over 4040 mm require the use of modules.

### Measuring lengths in millimeters

Available in measuring lengths from 440 mm to 50 m in 200 mm increments. Contact Fagor Automation for custom solutions if your application requires longer lengths.

### Model description:

- LA: Absolute linear encoders with SSI protocol for FAGOR and others.
- LAS: Absolute linear encoders with SSI protocol for SIEMENS® (Solution Line).
- LAF: Absolute linear encoders with FANUC® (01, 02 and αi) protocol.
- LAM: Absolute linear encoders with MITSUBISHI® CNC protocol.
- LAP: Absolute linear encoders with PANASONIC® (Matsushita) protocol.
- LAD: Absolute linear encoders with FeeDat® protocol for FAGOR and others.
- LAD + EC-PA-DQ1: Absolute linear encoders with DRIVE-CLiQ® protocol, for SIEMENS® (Solution Line).
- LAB: Absolute linear encoders with BiSS® protocol.

## Characteristics

	LA	LAS	LAF	LAM	LAP	LAD	LAD+ EC-PA-DQ1	LAB				
Measurement	Incremental: By means of a 40 µm-pitch stainless steel tape Absolute: Optical reading of sequential binary code											
Glass thermal expansion coefficient	$\alpha_{\text{therm}}$ : 11 ppm/K aprox.											
Measuring resolution	0.1 µm	1 µm	Interface α 0.05 µm 0.01 µm	Interface αd 0.0125 µm 0.00125 µm	0.01 µm	0.05 µm	0.01 µm	0.05 µm	0.01 µm	0.05 µm	0.01 µm	0.05 µm
Output signals	~ 1 Vpp		-		-		-		-		-	
Incremental signal period	40 µm		-		-		-		-		-	
Limit frequency	< 50 KHz for 1 Vpp		-		-		-		-		-	
Maximum cable length	75 m (*)	100 m	30 m		30 m	30 m	100 m	30 m	(**)			
Supply voltage	5V ± 10%, < 250 mA (without load)											
Steel tape accuracy	± 5 µm/m											
Maximum speed	120 m/min	180 m/min	180 m/min	180 m/min	180 m/min	180 m/min	180 m/min	180 m/min				
Maximum vibration	100 m/s <sup>2</sup>											
Maximum shock	300 m/s <sup>2</sup> (11 ms) IEC 60068-2-27											
Maximum acceleration	100 m/s <sup>2</sup> in the measuring direction											
Required moving force	< 5 N											
Operating temperature	0°C ... 50°C											
Storage temperature	-20°C ... 70°C											
Weight	1.50 kg + 4 kg/m											
Relative humidity	20 ... 80%											
Protection	IP 53 (standard) IP 64 (DIN 40050) using pressurized air at 0.8 ± 0.2 bar in linear encoders											
Reader head	With built-in connector Connection at both ends of the reader head											

(\*) Contact Fagor Automation for other lengths.

(\*\*) Contact Fagor Automation for maximum cable length.

## Single LA model

Dimensions in mm

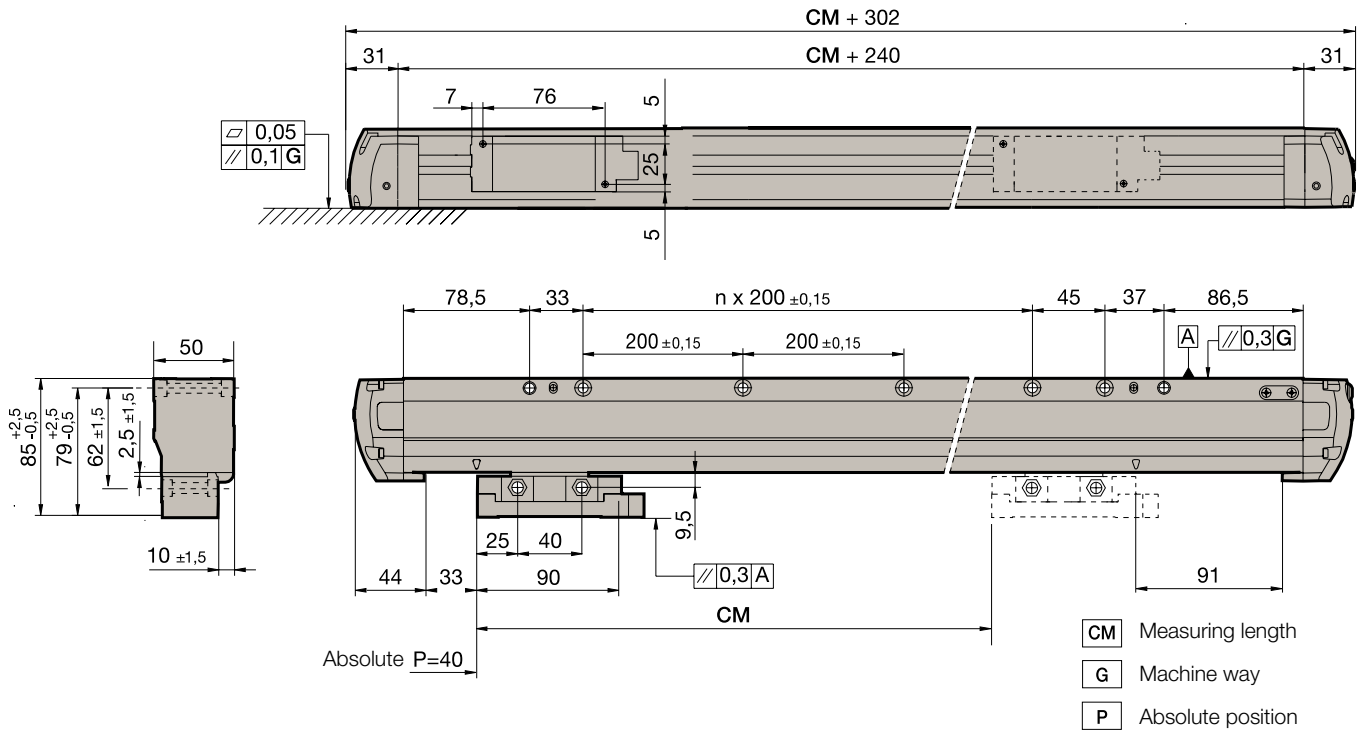

## Modular LA model

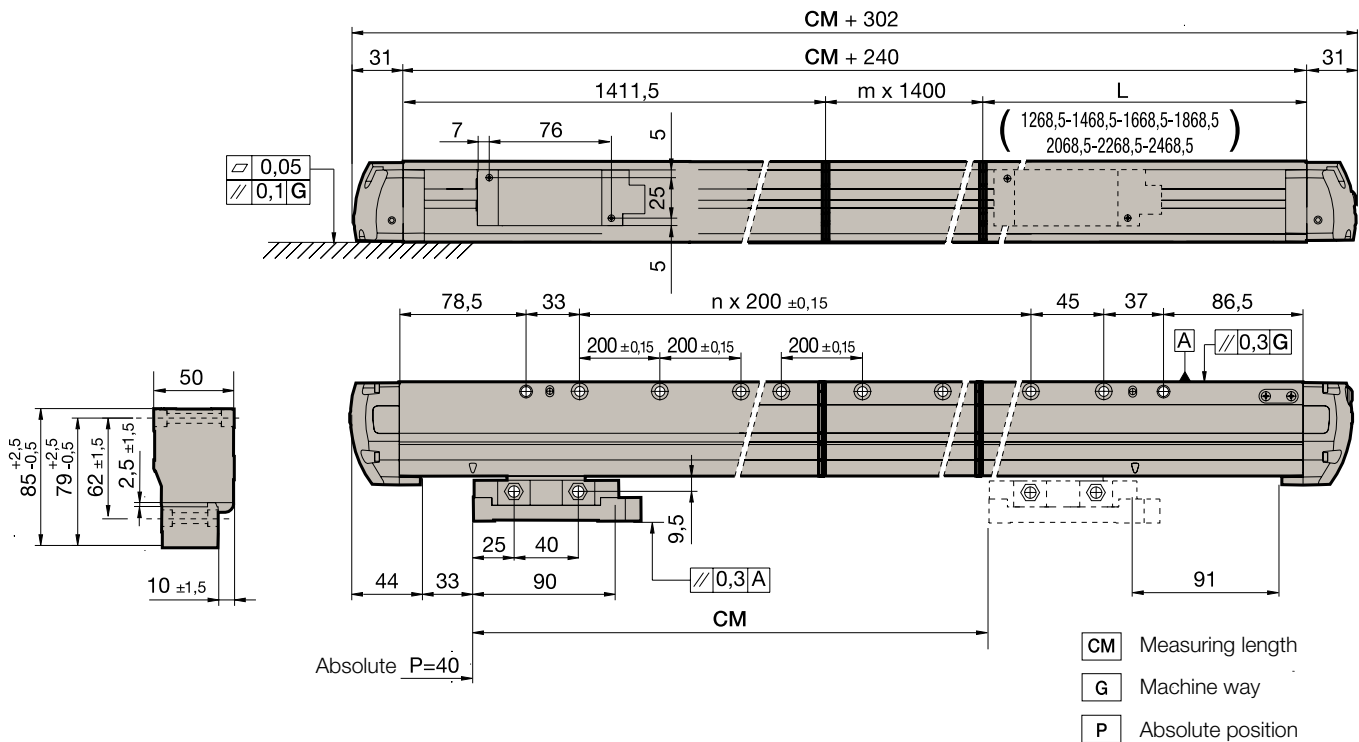

## Order identification

Example of Linear Encoder: LAF10-102-A

L	A	F	10	102	A
<b>Type of profile for long space</b>	<b>Letter identifying the absolute encoder</b>	<b>Type of communications protocol:</b>	<b>Resolution:</b>	<b>Ordering length code:</b>	<b>Air intake on the reader head:</b>
		<ul style="list-style-type: none"> <li>Blank space: SSI protocol (FAGOR)</li> <li>D: FeedDat® protocol (FAGOR) (*)</li> <li>S: SSI SIEMENS® (SL) protocol</li> <li><b>F: FANUC® (01, 02 and α) protocol</b></li> <li>M: MITSUBISHI® CNC protocol</li> <li>P: PANASONIC® (Matsushita) protocol</li> <li>B: BISS® protocol</li> </ul>	<ul style="list-style-type: none"> <li>Blank space: up to 0.1 μm (**)</li> <li>50: 0.05 μm</li> <li><b>10: 0.01 μm</b></li> </ul>	In the example (102) = 10240 mm	<ul style="list-style-type: none"> <li>Blank space: Without air intake</li> <li><b>A: With air intake</b></li> </ul>

(\*) plus EC-PA-DQ1 with DRIVE-CLIQ® protocol for SIEMENS® (Solution Line).

(\*\*) only for SSI models.

# G2A series



Linear encoder with small reader head, air intake and connector at both ends, with threaded head for different mounting options without the need for nuts.

Especially indicated for high standard environments in terms of speed and vibration.

Their special design of the securing points of the linear encoder (TDMS™), drastically reduces the errors and ensures the accuracy and repeatability of the encoders.

### Measuring lengths in millimeters

140 • 240 • 340 • 440 • 540 • 640 • 740 • 840 • 940 • 1 040 • 1 140 • 1 240 • 1 340 • 1 440 • 1 540 • 1 640 • 1 740 • 1 840 • 2 040 • 2 240 • 2 440 • 2 640 • 2 840 • 3 040

### Model description:

**G2A:** Absolute linear encoders with SSI protocol for FAGOR and others.

**G2AS:** Absolute linear encoders with SSI protocol for SIEMENS® (Solution Line).

**G2AF:** Absolute linear encoders with FANUC® (01, 02 and αi) protocol.

**G2AM:** Absolute linear encoders with MITSUBISHI® CNC protocol.

**G2AP:** Absolute linear encoders with PANASONIC® (Matsushita) protocol.

**G2AD:** Absolute linear encoders with FeeDat® protocol for FAGOR and others.

**G2AD + EC-PA-DQ1:** Absolute linear encoders with DRIVE-CLiQ® protocol, for SIEMENS® (Solution Line).

**G2AB:** Absolute linear encoders with BISS® protocol.

## Characteristics

	G2A / G2AS	G2AF	G2AM	G2AP	G2AD	G2AD+ EC-PA-DQ1	G2AB
<b>Measurement</b>	Incremental: By means of a 20 µm-pitch graduated glass tape Absolute: Optical reading of sequential binary code						
<b>Glass thermal expansion coefficient</b>	$\alpha_{\text{therm}}$ : 8 ppm/K aprox.						
<b>Measuring resolution</b>	0.1 µm	Interface αi 0.05 µm 0.01 µm	Interface αi 0.0125 µm 0.00125 µm	0.01 µm	0.05 µm	0.01 µm	0.05 µm
<b>Output signals</b>	~ 1 Vpp	–	–	–	–	–	–
<b>Incremental signal period</b>	20 µm	–	–	–	–	–	–
<b>Limit frequency</b>	< 100 kHz for 1 Vpp	–	–	–	–	–	–
<b>Maximum cable length</b>	75 m (*)   100 m	30 m	30 m	30 m	100 m	30 m	(**)
<b>Supply voltage</b>	5V ± 10%, < 250 mA (without load)						
<b>Accuracy</b>	± 5 µm/m ± 3 µm/m						
<b>Maximum speed</b>	180 m/min						
<b>Maximum vibration</b>	200 m/s <sup>2</sup> (55 ... 2000 Hz) IEC 60068-2-6						
<b>Maximum shock</b>	300 m/s <sup>2</sup> (11 ms) IEC 60068-2-27						
<b>Maximum acceleration</b>	100 m/s <sup>2</sup> in the measuring direction						
<b>Required moving force</b>	< 5 N						
<b>Operating temperature</b>	0°C ... 50°C						
<b>Storage temperature</b>	-20°C ... 70°C						
<b>Weight</b>	0.25 kg + 2.25 kg/m						
<b>Relative humidity</b>	20 ... 80%						
<b>Protection</b>	IP 53 (standard) IP 64 (DIN 40050) using pressurized air at 0.8 ± 0.2 bar in linear encoders						
<b>Reader head</b>	With built-in connector Connection at both ends of the reader head						

(\*) Contact Fagor Automation for other lengths.

(\*\*) Contact Fagor Automation for maximum cable length.

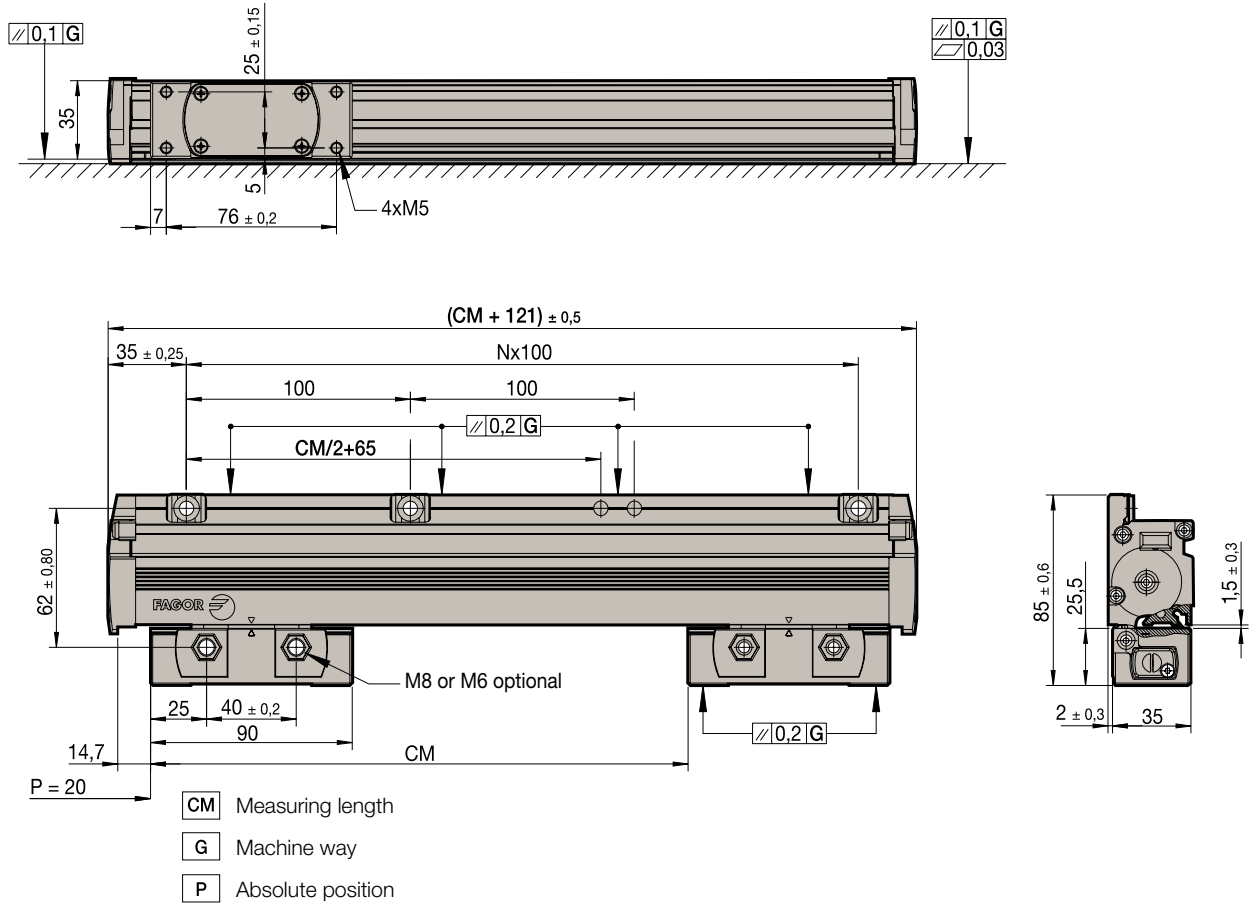

## Order identification

Example of Linear Encoder: **G2AF10-1640-5-A-T**

G2	A	F	10	1640	5	A	T
<b>Type of profile for ample space, small head</b>	<b>Letter identifying the absolute encoder</b>	<b>Type of communications protocol:</b> <ul style="list-style-type: none"> <li>Blank space: SSI protocol (FAGOR)</li> <li>D: FeedDat® protocol (FAGOR) (*)</li> <li>S: SSI SIEMENS® (SL) protocol</li> <li><b>F: FANUC® (01, 02 and α) protocol</b></li> <li>M: MITSUBISHI® CNC protocol</li> <li>P: PANASONIC® (Matsushita) protocol</li> <li>B: BISS® protocol</li> </ul>	<b>Resolution:</b> <ul style="list-style-type: none"> <li>Blank space: up to 0.1 μm (**)</li> <li>50: 0.05 μm</li> <li><b>10: 0.01 μm</b></li> </ul>	<b>Measuring lengths in millimeters:</b> In the example (1640) = 1 640 mm	<b>Accuracy of the linear encoder:</b> <ul style="list-style-type: none"> <li><b>5: ± 5 μm</b></li> <li>3: ± 3 μm</li> </ul>	<b>Air intake on the reader head:</b> <ul style="list-style-type: none"> <li><b>A: With air intake</b></li> </ul>	<b>Threaded head:</b> <ul style="list-style-type: none"> <li>Blank space: M8</li> <li><b>T: M6</b></li> </ul>

(\*) plus EC-PA-DQ1 with DRIVE-CLiQ® protocol for SIEMENS® (Solution Line).

(\*\*) only for SSI models.



# S2A series



Linear encoder with threaded head option for different mounting options without the need for nuts.  
Especially indicated for high standard environments in terms of speed and vibration.

### Measuring lengths in millimeters

70 • 120 • 170 • 220 • 270 • 320 • 370 • 420 • 470 • 520 • 570 • 620 • 670 • 720 • 770 • 820 • 870 • 920 • 1020 • 1140 • 1240

### Model description:

- S2A: Absolute linear encoders with SSI protocol for FAGOR and others.
- S2AS: Absolute linear encoders with SSI protocol for SIEMENS® (Solution Line).
- S2AF: Absolute linear encoders with FANUC® (01, 02 and αi) protocol.
- S2AM: Absolute linear encoders with MITSUBISHI® CNC protocol.
- S2AP: Absolute linear encoders with PANASONIC® (Matsushita) protocol.
- S2AD: Absolute linear encoders with FeeDat® protocol for FAGOR and others.
- S2AD + EC-PA-DQ1: Absolute linear encoders with DRIVE-CLiQ® protocol, for SIEMENS® (Solution Line).
- S2AB: Absolute linear encoders with BiSS® protocol.

## Characteristics

	S2A / S2AS	S2AF	S2AM	S2AP	S2AD	S2AD+ EC-PA-DQ1	S2AB				
Measurement	Incremental: By means of a 20 µm-pitch graduated glass tape Absolute: Optical reading of sequential binary code										
Glass thermal expansion coefficient	$\alpha_{\text{therm}}$ : 8 ppm/K aprox.										
Measuring resolution	0.1 µm	Interface αi 0.05 µm 0.01 µm	Interface Ci 0.0125 µm 0.00125 µm	0.01 µm	0.05 µm	0.01 µm	0.05 µm	0.01 µm	0.05 µm	0.01 µm	0.05 µm
Output signals	~ 1 Vpp	–	–	–	–	–	–	–	–	–	–
Incremental signal period	20 µm	–	–	–	–	–	–	–	–	–	–
Limit frequency	< 100 kHz for 1 Vpp	–	–	–	–	–	–	–	–	–	–
Maximum cable length	75 m (*)   100 m	30 m	30 m	30 m	100 m	30 m	(**)				
Supply voltage	5V ± 10%, < 250 mA (without load)										
Accuracy	± 5 µm/m ± 3 µm/m										
Maximum speed	180 m/min										
Maximum vibration	100 m/s <sup>2</sup> (55 ... 2000 Hz) IEC 60068-2-6										
Maximum shock	300 m/s <sup>2</sup> (11 ms) IEC 60068-2-27										
Maximum acceleration	100 m/s <sup>2</sup> in the measuring direction										
Required moving force	< 4 N										
Operating temperature	0°C ... 50°C										
Storage temperature	-20°C ... 70°C										
Weight	0.2 kg + 0.50 kg/m										
Relative humidity	20 ... 80%										
Protection	IP 53 (standard) IP 64 (DIN 40050) using pressurized air at 0.8 ± 0.2 bar in linear encoders										
Reader head	With built-in connector										

(\*) Contact Fagor Automation for other lengths.

(\*\*) Contact Fagor Automation for maximum cable length.

# S2A model

Dimensions in mm

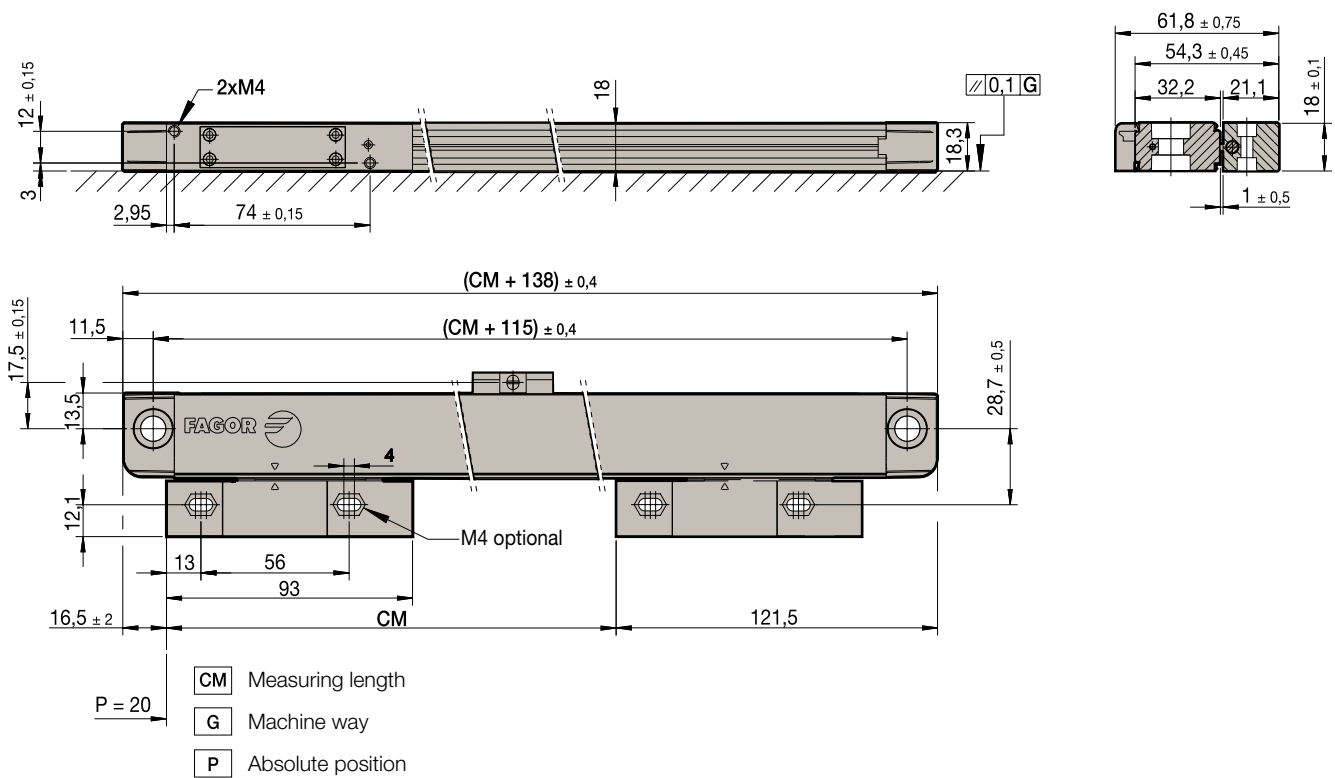

## Order identification

Example of Linear Encoder: **S2AM10-1140-5-A-T**

S2	A	M	10	1140	5	A	T
<p><b>Type of profile for reduced space:</b></p> <ul style="list-style-type: none"> <li>• S2: Standard mounting for vibrations of up to 100 m/s<sup>2</sup></li> </ul>	<p><b>Letter identifying the absolute encoder</b></p>	<p><b>Type of communications protocol:</b></p> <ul style="list-style-type: none"> <li>• Blank space: SSI protocol (FAGOR)</li> <li>• D: FeedDat<sup>®</sup> protocol (FAGOR) (*)</li> <li>• S: SSI SIEMENS<sup>®</sup> (SL) protocol</li> <li>• F: FANUC<sup>®</sup> (01, 02 and α) protocol</li> <li>• M: MITSUBISHI<sup>®</sup> CNC protocol</li> <li>• P: PANASONIC<sup>®</sup> (Matsushita) protocol</li> <li>• B: BISS<sup>®</sup> protocol</li> </ul>	<p><b>Resolution:</b></p> <ul style="list-style-type: none"> <li>• Blank space: up to 0.1 μm (**)</li> <li>• 50: 0.05 μm</li> <li>• 10: 0.01 μm</li> </ul>	<p><b>Measuring lengths in millimeters:</b></p> <p>In the example (1140) = 1140 mm</p>	<p><b>Accuracy of the linear encoder:</b></p> <ul style="list-style-type: none"> <li>• 5: ± 5 μm</li> <li>• 3: ± 3 μm</li> </ul>	<p><b>Air intake on the reader head:</b></p> <ul style="list-style-type: none"> <li>• A: With air intake</li> </ul>	<p><b>Threaded head:</b></p> <ul style="list-style-type: none"> <li>• Blank space: No</li> <li>• T: M4</li> </ul>

(\*) plus EC-PA-DQ1 with DRIVE-CLiQ<sup>®</sup> protocol for SIEMENS<sup>®</sup> (Solution Line).

(\*\*) only for SSI models.

# SV2A series



Linear encoder with threaded head option for different installation options without the need for nuts. Small mounting support that may be secured from the top or from the bottom for easier installation.

Especially indicated for high standard environments in terms of speed and vibration.

Their special design of the securing points of the linear encoder (TDMS™), drastically reduces the errors and ensures the accuracy and repeatability of the encoders.

### Measuring lengths in millimeters

- 70 • 120 • 170 • 220 • 270 • 320 • 370 • 420 • 470 • 520 • 570 • 620
- 670 • 720 • 770 • 820 • 870 • 920 • 970 • 1020 • 1070 • 1140
- 1240 • 1340 • 1440 • 1540 • 1640 • 1740 • 1840 • 2040

### Model description:

- SV2A: Absolute linear encoders with SSI protocol for FAGOR and others.
- SV2AS: Absolute linear encoders with SSI protocol for SIEMENS® (Solution Line).
- SV2AF: Absolute linear encoders with FANUC® (01, 02 and αi) protocol.
- SV2AM: Absolute linear encoders with MITSUBISHI® CNC protocol.
- SV2AP: Absolute linear encoders with PANASONIC® (Matsushita) protocol.
- SV2AD: Absolute linear encoders with FeedReader® protocol for FAGOR and others.
- SV2AD + EC-PA-DQ1: Absolute linear encoders with DRIVE-CLiQ® protocol, for SIEMENS® (Solution Line).
- SV2AB: Absolute linear encoders with BiSS® protocol.

## Characteristics

	SV2A / SV2AS	SV2AF	SV2AM	SV2AP	SV2AD	SV2AD+ EC-PA-DQ1	SV2AB				
Measurement	Incremental: By means of a 20 µm-pitch graduated glass tape Absolute: Optical reading of sequential binary code										
Glass thermal expansion coefficient	$\alpha_{\text{therm}}$ : 8 ppm/K aprox.										
Measuring resolution	0.1 µm	Interface C1 0.05 µm 0.01 µm	Interface C1 0.0125 µm 0.00125 µm	0.01 µm	0.05 µm	0.01 µm	0.05 µm	0.01 µm	0.05 µm	0.01 µm	0.05 µm
Output signals	~ 1 Vpp	–	–	–	–	–	–	–	–	–	–
Incremental signal period	20 µm	–	–	–	–	–	–	–	–	–	–
Limit frequency	< 100 kHz for 1 Vpp	–	–	–	–	–	–	–	–	–	–
Maximum cable length	75 m (*)   100 m	30 m	30 m	30 m	100 m	30 m	(**)				
Supply voltage	5V ± 10%, < 250 mA (without load)										
Accuracy	± 5 µm/m ± 3 µm/m										
Maximum speed	180 m/min										
Maximum vibration	200 m/s <sup>2</sup> (55 ... 2000 Hz) IEC 60068-2-6										
Maximum shock	300 m/s <sup>2</sup> (11 ms) IEC 60068-2-27										
Maximum acceleration	100 m/s <sup>2</sup> in the measuring direction										
Required moving force	< 4 N										
Operating temperature	0°C ... 50°C										
Storage temperature	-20°C ... 70°C										
Weight	0.25 kg + 1.55 kg/m										
Relative humidity	20 ... 80%										
Protection	IP 53 (standard) IP 64 (DIN 40050) using pressurized air at 0.8 ± 0.2 bar in linear encoders										
Reader head	With built-in connector										

(\*) Contact Fagor Automation for other lengths.

(\*\*) Contact Fagor Automation for maximum cable length.

# SV2A model

Dimensions in mm

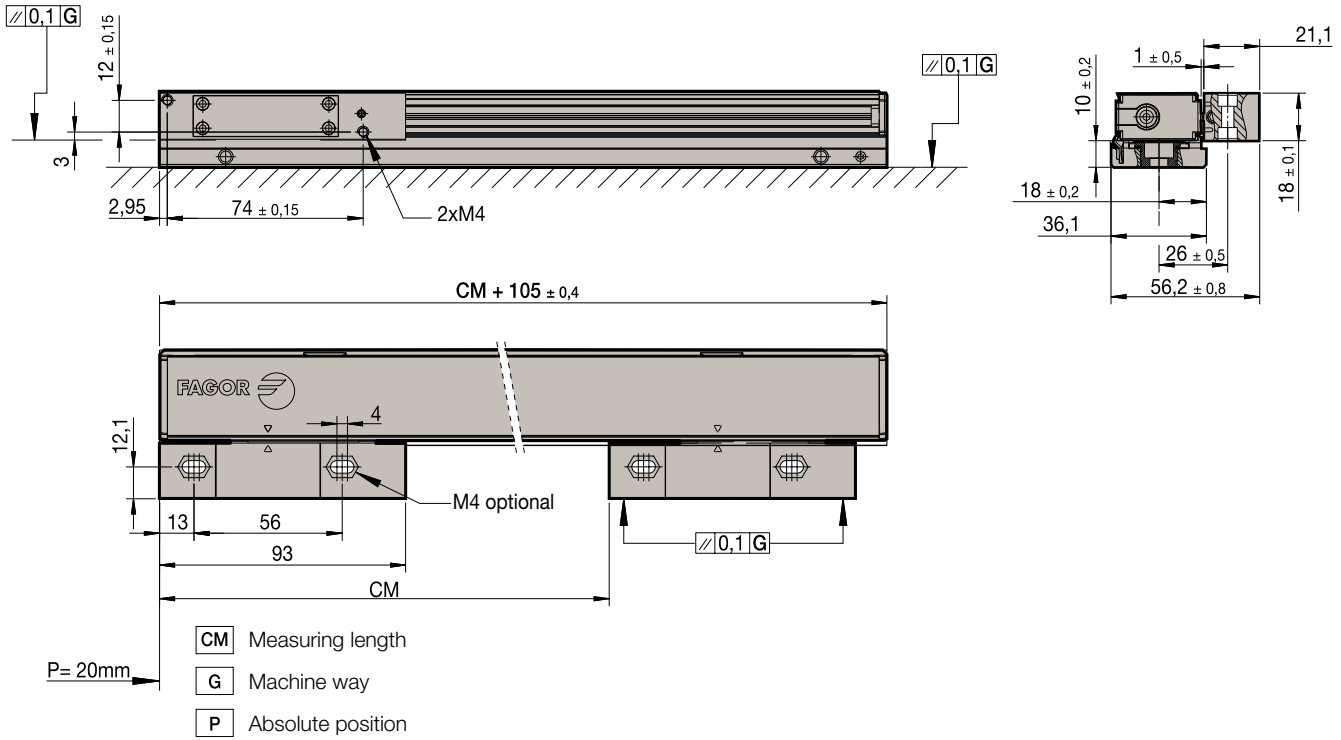

<b>CM</b>	70	120	170	220	270	320	370	420	470	520	570	620	670	720	770
<b>M</b>	37.5	55	75	100	115	140	175	200	225	250	275	300	325	350	375
<b>CM</b>	820	870	920	970	1020	1070	1140	1240	1340	1440	1540	1640	1740	1840	2040
<b>M</b>	400	425	450	475	500	515	555	610	655	710	760	810	855	910	1010

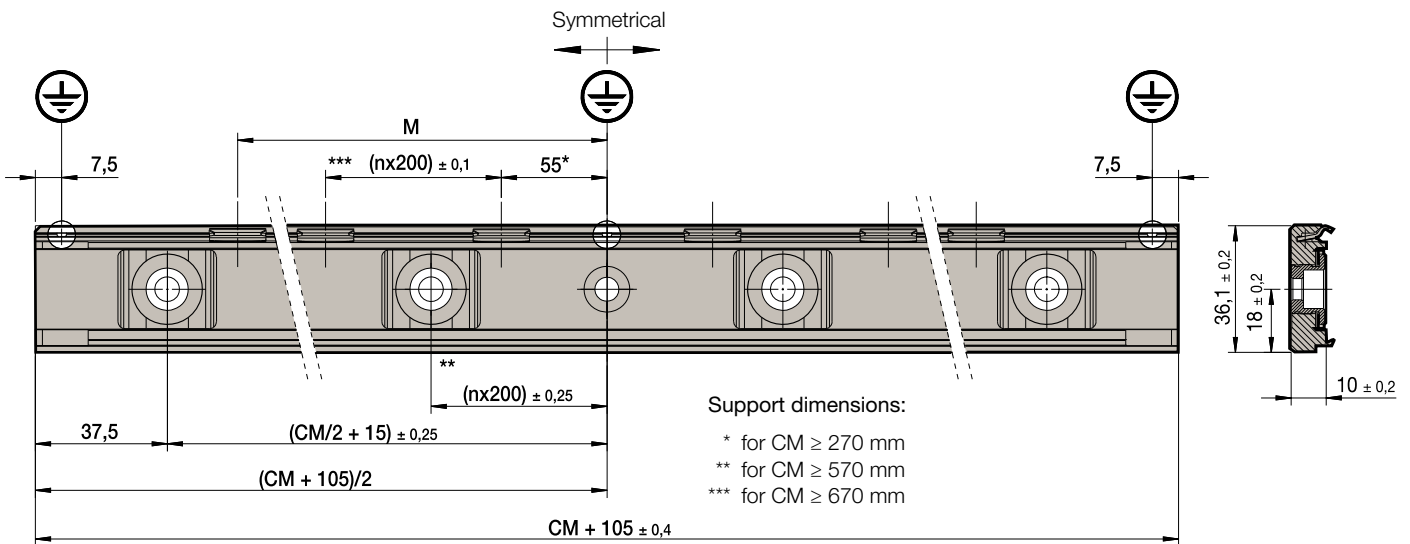

Support dimensions:  
 \* for CM ≥ 270 mm  
 \*\* for CM ≥ 570 mm  
 \*\*\* for CM ≥ 670 mm

## Order identification

Example of Linear Encoder: **SV2AF10-1640-5-B-A-T**

SV2	A	F	10	1640	5	B	A	T
<b>Type of profile for reduced spaces:</b> • SV2: Vibration mounting for up to 200 m/s <sup>2</sup>	<b>Letter identifying the absolute encoder</b>	<b>Type of communications protocol:</b> • Blank space: SSI protocol (FAGOR) • D: FeeDat® protocol (FAGOR) (*) • S: SSI SIEMENS® (SL) protocol • F: FANUC® (01, 02 and <i>ci</i> ) protocol • M: Protocolo MITSUBISHI® CNC • P: PANASONIC® (Matsushita) protocol • B: BISS® protocol	<b>Resolution:</b> • Blank space: up to 0.1 µm (**) • 50: 0.05 µm • 10: 0.01 µm	<b>Measuring lengths in millimeters:</b> In the example (1640) = 1640 mm	<b>Accuracy of the linear encoder:</b> • 5: ± 5 µm • 3: ± 3 µm	<b>Linear encoder with mounting support:</b> • B: With mounting support for vibrations of up to 200 m/s <sup>2</sup>	<b>Air intake on the reader head:</b> • A: With air intake	<b>Threaded head:</b> • Blank space: No • T: M4

(\*) plus EC-PA-DQ1 with DRIVE-CLIQ® protocol for SIEMENS® (Solution Line).  
 (\*\*) only for SSI models.

# direct connection cables

## SSI connection

### UP TO 9 METERS

Connector for direct connection to FAGOR

#### EC...B-D

Lengths: 1, 3, 6 and 9 meters

SUB D 15 HD connector (male Pin )

Pin	Signal	Color
1	A	Green
2	/A	Yellow
3	B	Blue
4	/B	Red
5	Data	Grey
6	/Data	Pink
7	Clock	Black
8	/Clock	Purple
9	+5 V	Brown
10	+5 V sensor	Light green
11	0 V	White
12	0 V sensor	Orange
15	Ground	Internal shield
Housing	Ground	External shield

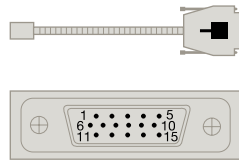

Connector for direct connection to SIEMENS® SMC20

#### EC-...B-S1

Lengths: 1, 3, 6 and 9 meters

SUB D 25 connector (female Pin )

Pin	Signal	Color
3	A	Green
4	/A	Yellow
6	B	Blue
7	/B	Red
15	Data	Grey
23	/Data	Pink
10	Clock	Black
12	/Clock	Purple
1	+5 V	Brown
14	+5 V sensor	Light green
2	0 V	White
16	0 V sensor	Orange
5	Ground	Internal shield
Housing	Ground	External shield

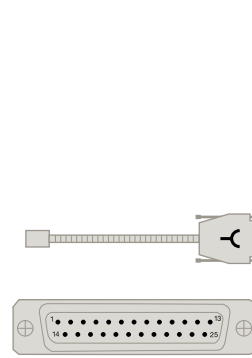

Connector for direct connection to SIEMENS® SME25

#### EC...B-C9

Lengths: 1, 3, 6 and 9 meters

CIRCULAR 17 connector (male Pin )

Pin	Signal	Color
15	A	Green
16	/A	Yellow
12	B	Blue
13	/B	Red
14	Data	Grey
17	/Data	Pink
8	Clock	Black
9	/Clock	Purple
7	+5 V	Brown
1	+5 V sensor	Light green
10	0 V	White
4	0 V sensor	Orange
11	Ground	Internal shield
Housing	Ground	External shield

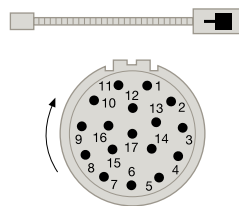



**FROM 9 METERS ON**

For connection to FAGOR: EC-...B-C9 cable + XC-C8-...F-D extension cable

For connection to SIEMENS® SMC20: EC-...B-C9 cable + XC-C8-...F-S1 extension cable

For connection to SIEMENS® SME25: EC-...B-C9 cable + XC-C8-...F-C9 extension cable

**EC...B-C9**

**Lengths:** 1 and 3 meters  
(consult Fagor Automation for others)

CIRCULAR 17 connector (male Pin )

Pin	Signal	Color
15	A	Green
16	/A	Yellow
12	B	Blue
13	/B	Red
14	Data	Grey
17	/Data	Pink
8	Clock	Black
9	/Clock	Purple
7	+5 V	Brown
1	+5 V sensor	Light green
10	0 V	White
4	0 V sensor	Orange
11	Ground	Internal shield
Housing	Ground	External shield

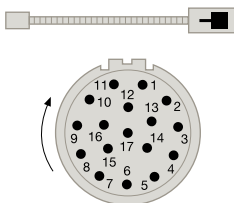

**XC-C8-...F-D extension cable**

**Lengths:** 5, 10, 15, 20 and 25 meters

CIRCULAR 17 connector (female Pin )

SUB D 15 HD connector (male Pin )

Pin	Pin	Signal	Color
15	1	A	Green/Black
16	2	/A	Yellow/Black
12	3	B	Blue/Black
13	4	/B	Red/Black
14	5	Data	Grey
17	6	/Data	Pink
8	7	Clock	Purple
9	8	/Clock	Yellow
7	9	+5 V	Brown/Green
1	10	+5 V sensor	Blue
10	11	0 V	White/Green
4	12	0 V sensor	White
11	15	Ground	Internal shield
Housing	Housing	Ground	External shield

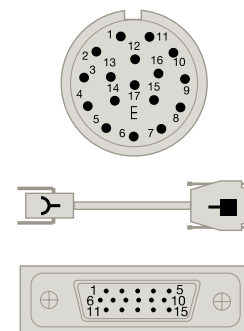

**XC-C8-...F-S1 extension cable**

**Lengths:** 5, 10, 15, 20 and 25 meters

CIRCULAR 17 connector (female Pin )

SUB D25 connector (female Pin )

Pin	Pin	Signal	Color
15	3	A	Green/Black
16	4	/A	Yellow/Black
12	6	B	Blue/Black
13	7	/B	Red/Black
14	15	Data	Grey
17	23	/Data	Pink
8	10	Clock	Purple
9	12	/Clock	Yellow
7	1	+5 V	Brown/Green
1	14	+5 V sensor	Blue
10	2	0 V	White/Green
4	16	0 V sensor	White
11	5	Ground	Internal shield
Housing	Housing	Ground	External shield

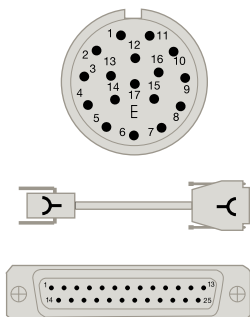

**XC-C8-...F-C9 extension cable**

**Lengths:** 5, 10, 15, 20 and 25 meters

CIRCULAR 17 connector (female Pin )

CIRCULAR 17 connector (male Pin )

Pin	Pin	Signal	Color
15	15	A	Green/Black
16	16	/A	Yellow/Black
12	12	B	Blue/Black
13	13	/B	Red/Black
14	14	Data	Grey
17	17	/Data	Pink
8	8	Clock	Purple
9	9	/Clock	Yellow
7	7	+5 V	Brown/Green
1	1	+5 V sensor	Blue
10	10	0 V	White/Green
4	4	0 V sensor	White
11	11	Ground	Internal shield
Housing	Housing	Ground	External shield

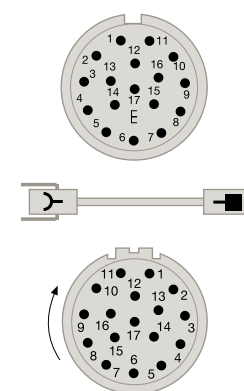

# direct connection cables

## Connection to other CNC's

UP TO 9 METERS

Connector for direct connection to FANUC®

### EC...PA-FN

Lengths: 1, 3, 6 and 9 meters

HONDA / HIROSE connector (female Pin )

Pin	Signal	Color
1	Data	Green
2	/Data	Yellow
5	Request	Blue
6	/Request	Red
9	+5 V	Brown
18-20	+5 V sensor	Grey
12	0 V	White
14	0 V sensor	Pink
16	Ground	Shield

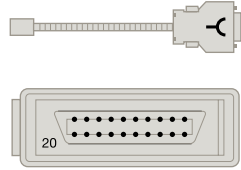

Connector for direct connection to MITSUBISHI®

### EC...AM-MB

Lengths: 1, 3, 6 and 9 meters

10-pin MOLEX/3M RECTANGULAR connector (female Pin )

Pin	Signal	Color
7	SD (MD)	Green
8	/SD (MD)	Yellow
3	RQ (MR)	Grey
4	/RQ (MR)	Pink
1	+5 V	Brown + purple
2	0 V	White + black + blue
Housing	Ground	Shield

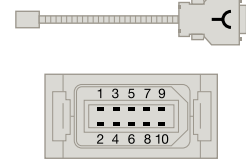

Connector for direct connection to PANASONIC® MINAS A5

### EC-...PA-PN5

Lengths: 1, 3, 6 and 9 meters

PANASONIC 10 pin connector (female Pin )

Pin	Signal	Color
3	Data	Green
4	/Data	Yellow
1	+5 V	Brown + grey
2	0 V	White + pink
Housing	Ground	Shield

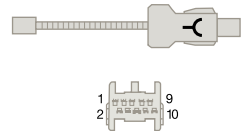

Connector for connection with extension cable (M12 H-RJ45) to SIEMENS® Sinamics/Sinumerik

### EC-...PA-DQ1

Lengths: 1, 3, 6 and 9 meters

Pin	Signal
3	RXP
4	RXN
6	TXN
7	TXP
1	Vcc (24 V)
2	0 V



## FROM 9 METERS ON

For connection to FANUC®: EC... B-C9 cable+ XC-C8... FN extension cable

For connection to MITSUBISHI®: EC... B-C9-F cable + XC-C8... MB extension cable

For connection to PANASONIC® MINAS A5: EC... B-C9 cable + XC-C8... A-PN5 extension cable

For connection to SIEMENS®: EC... PA-DQ1 cable + (M12 H-RJ45) extension cable

### EC... B-C9

Lengths: 1 and 3 meters  
(consult Fagor Automation for others)

CIRCULAR 17 connector (male Pin )

Pin	Signal	Color
14	Data	Grey
17	/Data	Pink
8	Request	Black
9	/Request	Purple
7	+5 V	Brown
1	+5 V sensor	Light green
10	0 V	White
4	0 V sensor	Orange
Housing	Ground	Shield

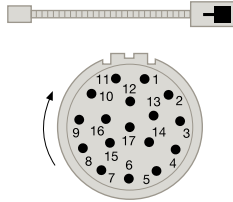

### EC... B-C9-F

Lengths: 1 and 3 m with Ferrite  
(consult Fagor Automation for others)

CIRCULAR 17 connector (male Pin )

Pin	Signal	Color
14	Data	Grey
17	/Data	Pink
8	Request	Black
9	/Request	Purple
7	+5 V	Brown
1	+5 V sensor	Light green
10	0 V	White
4	0 V sensor	Orange
Housing	Ground	Shield

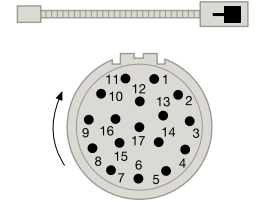

### XC-C8... FN extension cable

Lengths: 5, 10, 15, 20 and 25 meters

CIRCULAR 17 connector (female Pin )

HONDA / HIROSE connector (female Pin )

Pin	Pin	Signal	Color
14	1	Data	Grey
17	2	/Data	Pink
8	5	Request	Purple
9	6	/Request	Yellow
7	9	+5 V	Brown/Green
1	18-20	+5 V sensor	Blue
10	12	0 V	White/Green
4	14	0 V sensor	White
Housing	16	Ground	Shield

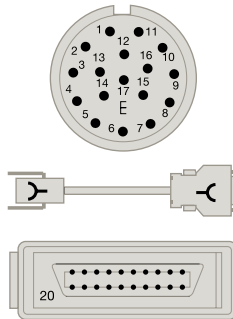

### XC-C8... MB extension cable

Lengths: 5, 10, 15, 20 and 25 meters

CIRCULAR 17 connector (female Pin )

10-pin MOLEX/3M RECTANGULAR connector (female Pin )

Pin	Pin	Signal	Color
8	7	SD (MD)	Purple
9	8	/SD (MD)	Yellow
14	3	RQ (MR)	Grey
17	4	/RQ (MR)	Pink
7	1	+5 V	Brown/Green
1	1	+5 V sensor	Blue
10	2	GND	White/Green
4	2	0 V sensor	White
12	2	SEL	Black
Housing	Housing	Ground	Shield

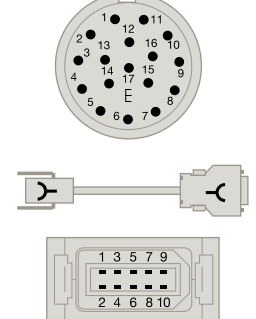

### XC-C8... A-PN5 extension cable

Lengths: 5, 10, 15, 20 and 25 meters

CIRCULAR 17 connector (female Pin )

PANASONIC 10 pin connector (female Pin )

Pin	Pin	Signal	Color
14	3	Data	Grey
17	4	/Data	Pink
7	1	+5 V	Brown+Black
1	1	+5 V sensor	Green+Yellow
10	2	GND	White+Purple
4	2	GND sensor	Blue+Red
Housing	Housing	Ground	Shield

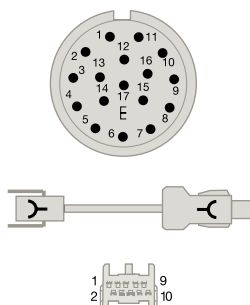



# Range

**Analyze the application to make sure that the proper encoder will be selected for the machine.**

To do this, bear in mind the following considerations

**Installation:** Consider the physical length of the installation and the space available for it. These aspects are crucial to determine the type of linear encoder to use (type of profile).

**Accuracy:** Each linear encoder comes with a graph showing its accuracy along its measuring length.

**Signal:** Consider the following variables for selecting the type of signal: Resolution, cable length and compatibility.

**Resolution:** The resolution of the control of machine-tools depends on the linear encoder.

**Cable length:** The length of the cable depends on the type of signal.

**Speed:** The speed requirements for the application must be analyzed before choosing the linear encoder.

**Shock and Vibration:** Fagor linear encoders withstand vibrations of up to 200 m/s<sup>2</sup> and shocks of up to 300 m/s<sup>2</sup>.

**Alarm signal:** Models S2W / S2OW and G2W / G2OW offer the alarm signal AL.

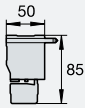
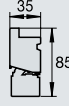
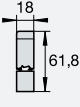
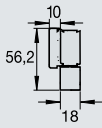
Series	Section	Measuring lengths
L Long		400 mm to 60 m
G2 Wide		140 mm to 3 040 mm
S2 Reduced		70 mm to 1 240 mm
SV2 Reduced		70 mm to 2 040 mm

# Technology

**The incremental encoders provide direct measure of machine position without using any intermediate device.**

The positioning errors originating from machine mechanics are minimized as the encoder is directly mounted to the machine surface and the guide ways. The encoder sends the real machine movement data to the CNC and mechanical errors caused due to thermal behavior of the machine, pitch error compensation and backlash etc. are minimized.

## Measuring Methods

Fagor Automation uses two measuring methods in their incremental encoders:

- Graduated glass:** Linear encoders with a measuring length of up to 3 040 mm use optical transmission. The light from the LED goes through a graduated glass and a reticule before reaching the receiving photo diodes. The period of the generated electrical signals is the same as the graduation pitch.
- Graduated steel:** Linear encoders over 3 040 mm measuring length use graduated steel tape and image captured through diffused light as a measuring principle. The reading system consists of an LED as a light source, a mesh to make the image and a monolithic photo detector element in the plane of the image specially designed and patented by Fagor Automation.

Graduated glass encoder

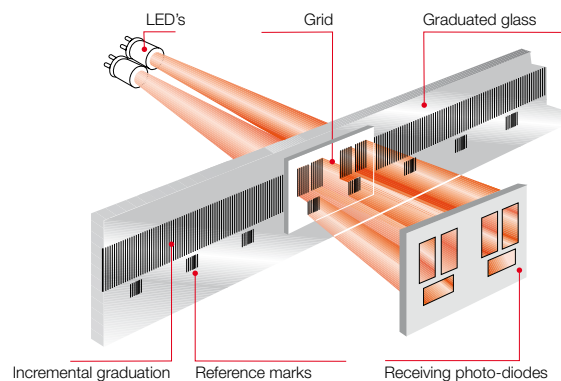

Graduated steel encoder

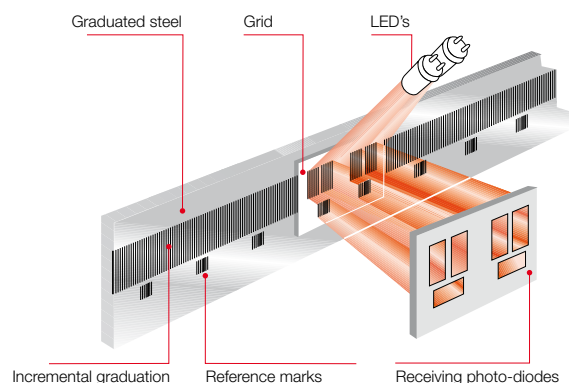

Accuracy	Signals	Pitch Resolution up to	Model	Page
± 5 μm	~ 1 Vpp	0.1 μm	LP / LOP	30
	⌋ TTL	1 μm	LX / LOX	
± 5 μm and ± 3 μm	~ 1 Vpp	0.1 μm	G2P / G2OP	32
	⌋ TTL	1 μm	G2X / G2OX	
	⌋ TTL	0.5 μm	G2Y / G2OY	
	⌋ TTL	0.1 μm	G2W / G2OW	
	⌋ TTL	0.05 μm	G2Z / G2OZ	
± 5 μm and ± 3 μm	~ 1 Vpp	0.1 μm	S2P / S2OP	34
	⌋ TTL	1 μm	S2X / S2OX	
	⌋ TTL	0.5 μm	S2Y / S2OY	
	⌋ TTL	0.1 μm	S2W / S2OW	
	⌋ TTL	0.05 μm	S2Z / S2OZ	
± 5 μm and ± 3 μm	~ 1 Vpp	0.1 μm	SV2P / SV2OP	36
	⌋ TTL	1 μm	SV2X / SV2OX	
	⌋ TTL	0.5 μm	SV2Y / SV2OY	
	⌋ TTL	0.1 μm	SV2W / SV2OW	
	⌋ TTL	0.05 μm	SV2Z / SV2OZ	

### Linear encoder

Incremental

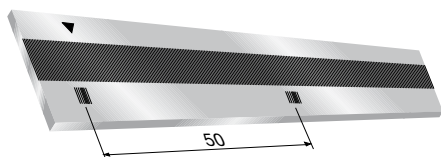

Distance-coded

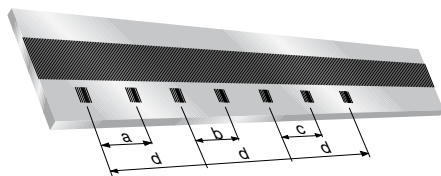

Series	Distances			
	a	b	c	d
L	40.04	40.08	40.12	80
G2 and S2	10.02	10.04	10.06	20

### Reference signals (I<sub>0</sub>)

It is a reference signal etched on a graduation and when scanned by the measuring system generates a pulse. Reference marks are used to validate and restore the machine zero position specially after turning on the machine power.

Fagor Automation encoders have three types of reference marks I<sub>0</sub>:

- **Incremental:** One reference mark signal every 50 mm of travel. The reference signal obtained is synchronized with the feedback signals to ensure perfect measuring repeatability.
- **Distance-coded:** Each distance coded reference signal is graduated in a non linear way based on the predefined mathematical function. The machine position value can be restored by moving through two consecutive reference signals. The machine movement needed to know the real position is always very small and this is a very useful feature for large travel machines.

# Electrical output signals

## Differential TTL

These are complementary signals in compliance with the EIA standard RS-422. This characteristic together with a line termination of 120 Ω, twisted pair, and an overall shield provide greater immunity to electromagnetic noise caused by their environment.

### Characteristics

Signals	A, /A, B, /B, I <sub>0</sub> , /I <sub>0</sub>
Signal level	V <sub>H</sub> ≥ 2.5V I <sub>H</sub> = 20 mA V <sub>L</sub> ≤ 0.5V I <sub>L</sub> = 20 mA With 1 m cable
90° reference signal (I <sub>0</sub> )	Synchronized with A and B
Switching time	t <sub>+</sub> /t <sub>-</sub> < 30 ns With 1 m cable
Supply voltage and consumption	5 V ± 5%, <150 mA
T period	4, 2, 0.4, 0.2 μm
Max. cable length	50 meters
Load impedance	Z <sub>0</sub> = 120 Ω between differential

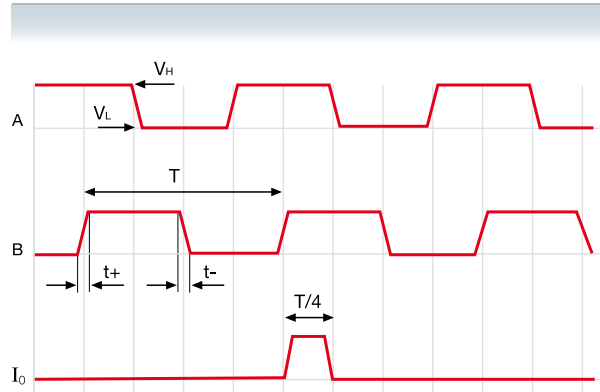

## Voltage drop across cable

The voltage required for a TTL encoder must be 5V ± 5%. A simple formula may be used to calculate the maximum cable length depending on the section of the supply cables.

$$L_{max} = (V_{CC} - 4.75) * 500 / (Z_{CABLE/Km} * I_{MAX})$$

### Example

V<sub>CC</sub> = 5V, I<sub>MAX</sub> = 0.1 Amp

Z (1 mm <sup>2</sup> )	=	16.6 Ω/Km	<b>(L<sub>max</sub> = 75 m)</b>
Z (0.5 mm <sup>2</sup> )	=	32 Ω/Km	<b>(L<sub>max</sub> = 39 m)</b>
Z (0.25 mm <sup>2</sup> )	=	66 Ω/Km	<b>(L<sub>max</sub> = 19 m)</b>
Z (0.14 mm <sup>2</sup> )	=	132 Ω/Km	<b>(L<sub>max</sub> = 9 m)</b>
Z (0.09 mm <sup>2</sup> )	=	232 Ω/Km	<b>(L<sub>max</sub> = 5 m)</b>

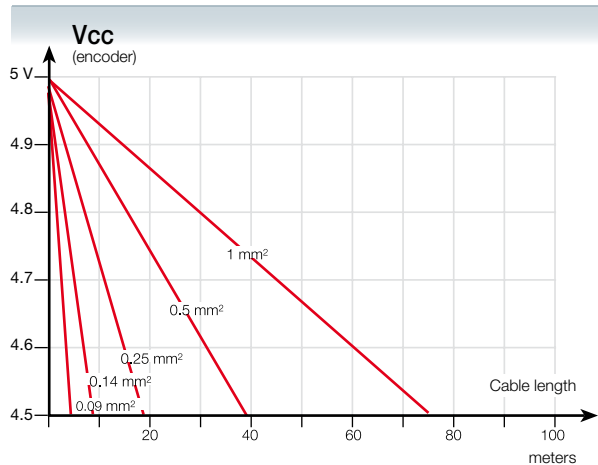

## Differential 1 Vpp

They are complementary sinusoidal signals whose differential value is 1 Vpp centered on  $V_{CC/2}$ . This characteristic together with a line termination of  $120 \Omega$ , twisted pair, and an overall shield provide greater immunity to electromagnetic noise caused by their environment.

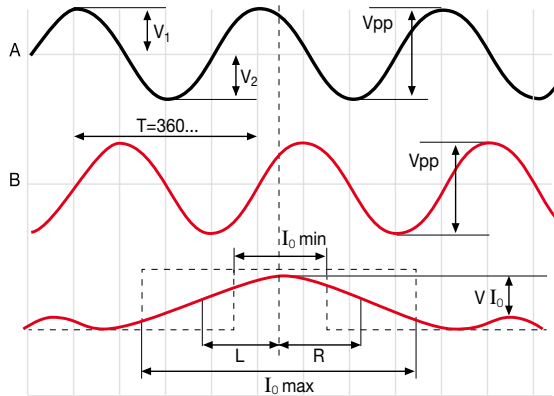

### Characteristics

Signals	A, /A, B, /B, I <sub>0</sub> / I <sub>0</sub>
V <sub>App</sub>	1 V +20%, -40%
V <sub>Bpp</sub>	1 V +20%, -40%
DC offset	2.5 V ± 0.5 V
Signal period	20 μm, 40 μm
Supply V	5 V ± 10%, <150 mA
Max. cable length	150 meters
A, B centered: $ V_1 - V_2  / 2 V_{pp}$	≤ 0.065
A&B relationship: $V_{App} / V_{Bpp}$	0.8 ÷ 1.25
A&B phase shift:	90° ± 10°
I <sub>0</sub> amplitude: V I <sub>0</sub>	0.2 ÷ 0.8 V
I <sub>0</sub> width: L + R	I <sub>0_min</sub> : 180° I <sub>0_typ</sub> : 360° I <sub>0_max</sub> : 540°
I <sub>0</sub> synchronism: L, R	180° ± 90°

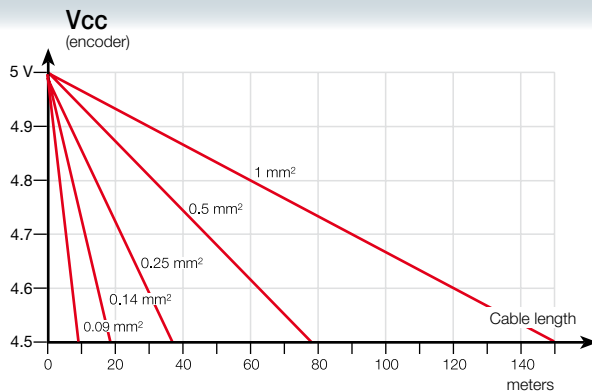

### Voltage drop across cable

The voltage required for a 1 Vpp encoder must be  $5 V \pm 10\%$ . A simple formula may be used to calculate the maximum cable length depending on the section of the supply cables:

$$L_{max} = (V_{CC} - 4.5) * 500 / (Z_{CABLE/Km} * I_{MAX})$$

### Example

$V_{CC} = 5V$ ,  $I_{MAX} = 0.1Amp$

Z (1 mm <sup>2</sup> )	=	16.6 Ω/Km	<b>(L<sub>max</sub>= 150 m)</b>
Z (0.5 mm <sup>2</sup> )	=	32 Ω/Km	<b>(L<sub>max</sub>= 78 m)</b>
Z (0.25 mm <sup>2</sup> )	=	66 Ω/Km	<b>(L<sub>max</sub>= 37 m)</b>
Z (0.14 mm <sup>2</sup> )	=	132 Ω/ Km	<b>(L<sub>max</sub>= 18 m)</b>
Z (0.09 mm <sup>2</sup> )	=	232 Ω/ Km	<b>(L<sub>max</sub>= 10 m)</b>

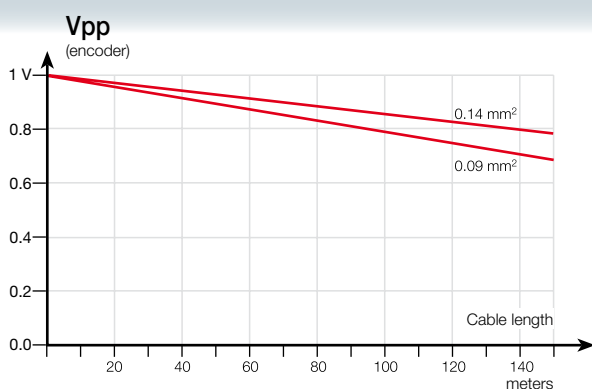

### 1 Vpp signal damping due to the cable section

Besides attenuation due to signal frequency, there is another signal attenuation caused by the section of the cable connected to the encoder.

# L series



Specially designed for high performance environment requiring speed and accuracy.

Their special mounting system guarantees a thermal behavior identical to that of the machine surface the linear encoder is mounted on. This is achieved through floating fixtures at their ends with the base of the machine and by tensioning the etched steel tape. This system eliminates the errors caused by temperature changes and ensures maximum accuracy and repeatability of the linear encoders.

The steel tape graduation pitch is 40 µm. Measuring lengths over 4 040 mm require the use of modules.

### Measuring lengths

Available in measuring lengths from 440 mm to 60 m in 200 mm increments. Contact Fagor Automation for custom solutions if your application requires longer lengths than 60 meters.

## Characteristics

	LX	LP
Measurement	By means of a 40 µm-pitch stainless steel tape	
Steel tape thermal expansion coefficient	$\alpha_{\text{therm}}$ : 11 ppm/K aprox.	
Measuring resolution	1 µm	Up to 0.1 µm
Output signals	□ □ TTL differential	~ 1 Vpp
Incremental signal period	4 µm	40 µm
Limit frequency	500 KHz	50 KHz
Maximum speed	120 m/min	120 m/min
Minimum distance between flanks	0.2 µs	-
Reference marks $I_0$	LX and LP: every 50 mm LOX and LOP: distance-coded $I_0$	
Maximum cable length	50 m	150 m
Supply voltage	5 V ± 5%, < 150 mA (without load)	5 V ± 10%, < 150 mA (without load)
Steel tape accuracy	± 5 µm/m	± 5 µm/m
Maximum vibration	100 m/s <sup>2</sup> (55 ... 2000 Hz) IEC 60068-2-6	
Maximum shock	300 m/s <sup>2</sup> (11 ms) IEC 60068-2-27	
Maximum acceleration	100 m/s <sup>2</sup> in the measuring direction	
Required moving force	< 5 N	
Operating temperature	0°C ... 50°C	
Storage temperature	-20°C ... 70°C	
Weight	1.50 kg + 4 kg/m	
Relative humidity	20 ... 80%	
Protection	IP 53 (standard) IP 64 (DIN 40050) using pressurized air at 0.8 ± 0.2 bar in linear encoders	
Reader head	With built-in connector Connection at both ends of the reader head	

# Single L model

Dimensions in mm

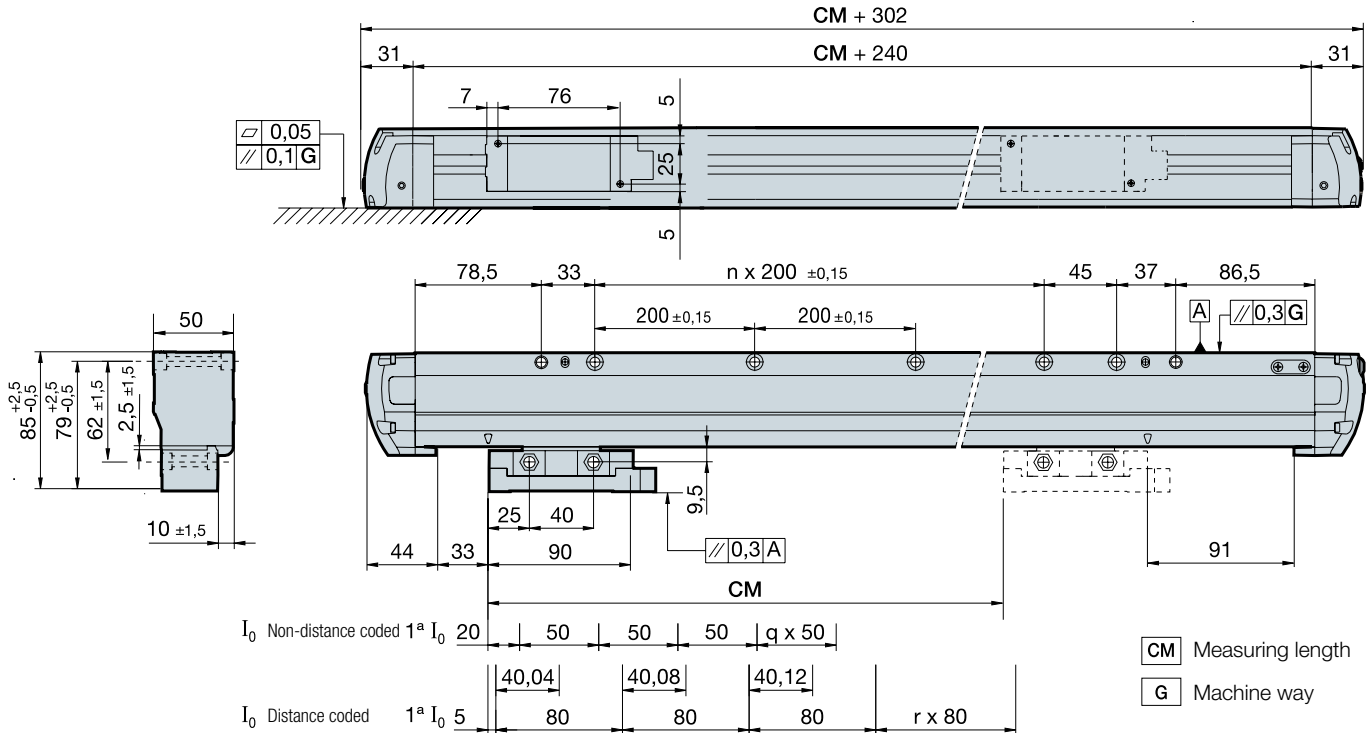

# Modular L model

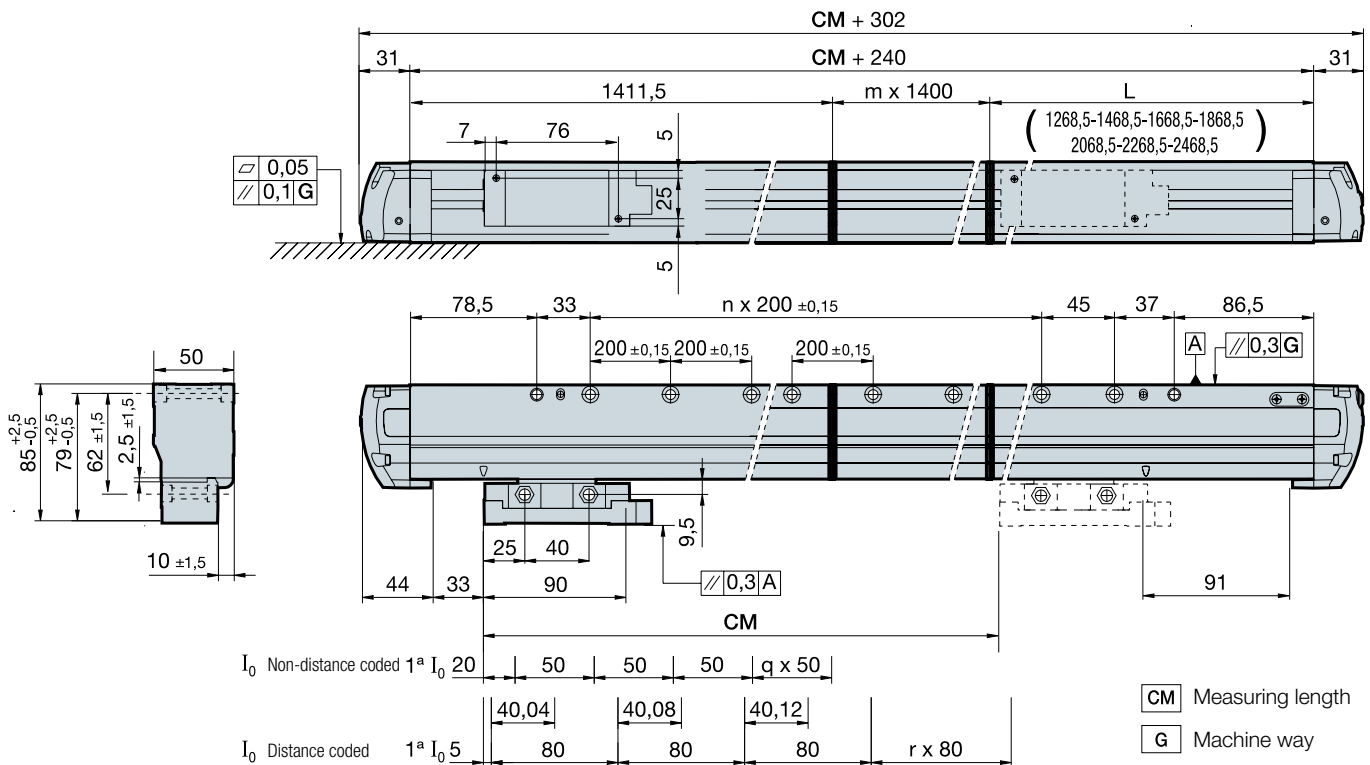

## Order identification

Example of Linear Encoder LOP - 102 - A

L	O	P	102	A
<b>Type of profile for long space</b>	<b>Type of reference mark <math>I_0</math>:</b> <ul style="list-style-type: none"> <li>Blank space: Incremental, one mark every 50 mm</li> <li><b>O</b>: Distance-coded marks</li> </ul>	<b>Type of signal:</b> <ul style="list-style-type: none"> <li><b>X</b>: 1 <math>\mu</math>m resolution differential TTL</li> <li><b>P</b>: 1 Vpp sinusoidal</li> </ul>	<b>Ordering length code:</b> In the example (102) = 10240 mm	<b>Air intake on the reader head:</b> <ul style="list-style-type: none"> <li>Blank space: Without air intake</li> <li><b>A</b>: With air intake</li> </ul>

# G2 series



Linear encoder with small reader head, air intake and connector at both ends, with threaded head for different mounting options without the need for nuts.

Especially indicated for high standard environments in terms of speed and vibration.

Their special design of the securing points of the linear encoder (TDMS™), drastically reduces the errors and ensures the accuracy and repeatability of the encoders.

### Measuring lengths in millimeters

140 • 240 • 340 • 440 • 540 • 640 • 740 • 840 • 940 • 1 040 • 1 140 • 1 240 • 1 340 • 1 440 • 1 540 • 1 640 • 1 740 • 1 840 • 2 040 • 2 240 • 2 440 • 2 640 • 2 840 • 3 040

Characteristics					
	G2X	G2Y	G2W	G2Z	G2P
Measurement	By means of a 20 µm-pitch graduated glass				
Glass thermal expansion coefficient	$\alpha_{\text{therm}}$ : 8 ppm/K aprox.				
Measuring resolution	1 µm	0.5 µm	0.1 µm	0.05 µm	Up to 0.1 µm
Output signals	□ □ TTL differential	□ □ TTL differential	□ □ TTL differential	□ □ TTL differential	~ 1 Vpp
Incremental signal period	4 µm	2 µm	0.4 µm	0.2 µm	20 µm
Limit frequency	500 KHz	1 MHz	1,5 MHz	500 KHz	100 KHz
Maximum speed	120 m/min	120 m/min	36 m/min	6 m/min (*)	120 m/min
Minimum distance between flanks	0.2 µs	0.2 µs	0.1 µs	0.3 µs	–
Reference marks I <sub>0</sub>	G2X, G2Y, G2W, G2Z and G2P: every 50 mm G2OX, G2OY, G2OW, G2OZ and G2OP: distance-coded I <sub>0</sub>				
Maximum cable length	50 m	50 m	50 m	50 m	150 m
Supply voltage	5 V ± 5%, < 150 mA (without load)	5 V ± 5%, < 150 mA (without load)	5 V ± 5%, < 150 mA (without load)	5 V ± 5%, < 150 mA (without load)	5 V ± 10%, < 150 mA (without load)
Accuracy	± 5 µm/m ± 3 µm/m				
Maximum vibration	200 m/s <sup>2</sup> (55 ... 2000 Hz) IEC 60068-2-6				
Maximum shock	300 m/s <sup>2</sup> (11 ms) IEC 60068-2-27				
Maximum acceleration	100 m/s <sup>2</sup> in the measuring direction				
Required moving force	< 5 N				
Operating temperature	0°C ... 50°C				
Storage temperature	-20°C ... 70°C				
Weight	0.25 kg + 2.25 kg/m				
Relative humidity	20 ... 80%				
Protection	IP 53 (standard) IP 64 (DIN 40050) using pressurized air at 0.8 ± 0.2 bar in linear encoders				
Reader head	With built-in connector Connection at both ends of the reader head				

(\*): contact Fagor Automation for higher speed.

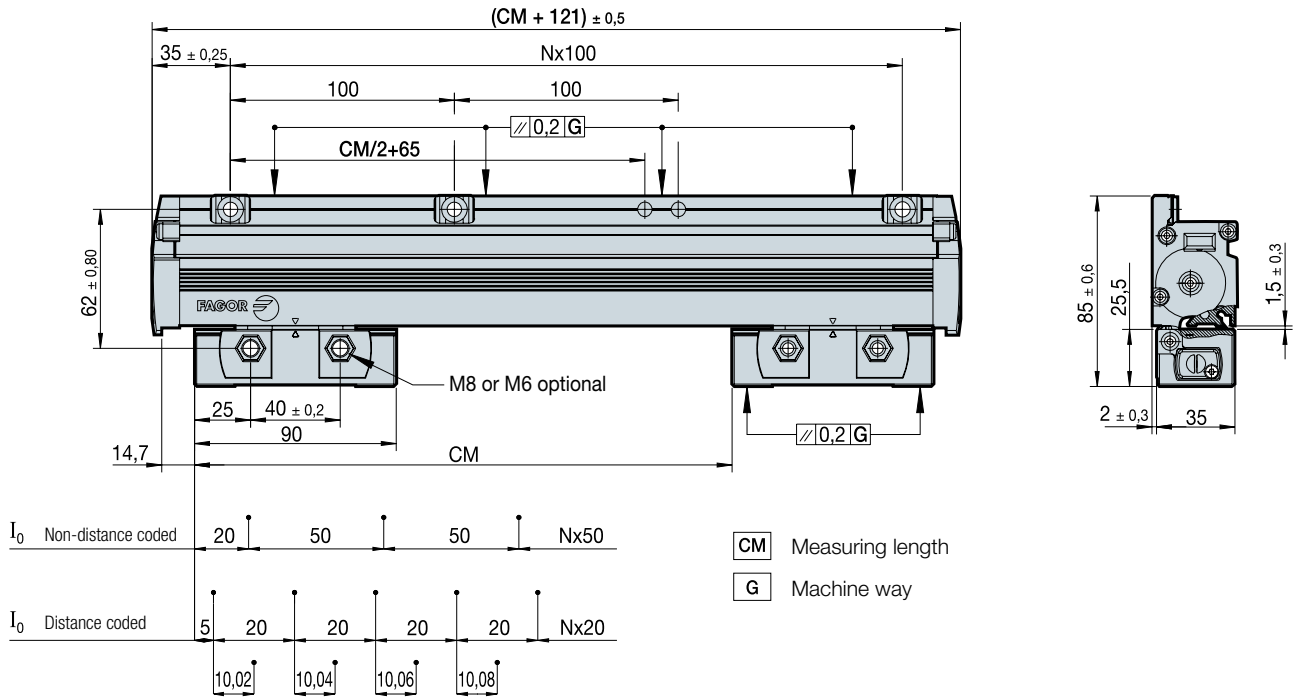
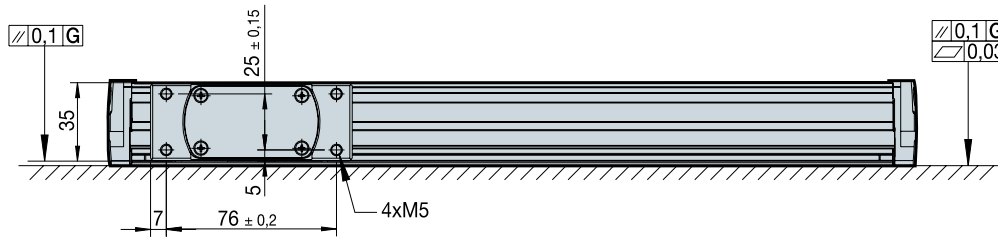

**CM** Measuring length  
**G** Machine way

### Order identification

Example of Linear Encoder: **G20X-1640-5-A-T**

G2	0	X	1640	5	A	T
<b>Type of profile for wide space</b>	<b>Type of reference mark I<sub>0</sub>:</b> • Blank space: Incremental, one mark every 50 mm • <b>0</b> : Distance-coded marks	<b>Type of signal:</b> • <b>X</b> : 1 μm resolution differential TTL • <b>Y</b> : 0.5 μm resolution differential TTL • <b>W</b> : 0.1 μm resolution differential TTL • <b>Z</b> : 0.05 μm resolution differential TTL • <b>P</b> : 1 Vpp sinusoidal	<b>Measuring lengths in millimeters:</b> In the example (1640) = 1 640 mm	<b>Accuracy of the linear encoder:</b> • 5: ± 5 μm • 3: ± 3 μm	<b>Air intake on the reader head:</b> • <b>A</b> : With air intake	<b>Threaded head:</b> • Blank space: M8 • <b>T</b> : M6



# S2 series



Linear encoder with threaded head option for different mounting options without the need for nuts.

Especially indicated for high standard environments in terms of speed and vibration.

### Measuring lengths in millimeters

70 • 120 • 170 • 220 • 270 • 320 • 370 • 420 • 470 • 520 • 570 • 620 • 670 • 720 • 770 • 820 • 870 • 920 • 1 020 • 1 140 • 1 240

## Characteristics

	S2X	S2Y	S2W	S2Z	S2P
Measurement	By means of a 20 µm-pitch graduated glass				
Glass thermal expansion coefficient	$\alpha_{\text{therm}}$ : 8 ppm/K aprox.				
Measuring resolution	1 µm	0.5 µm	0.1 µm	0.05 µm	Up to 0.1 µm
Output signals	□ TTL differential	□ TTL differential	□ TTL differential	□ TTL differential	~ 1 Vpp
Incremental signal period	4 µm	2 µm	0.4 µm	0.2 µm	20 µm
Limit frequency	500 KHz	1 MHz	1.5 MHz	500 KHz	100 KHz
Maximum speed	120 m/min	120 m/min	36 m/min	6 m/min (*)	120 m/min
Minimum distance between flanks	0.2 µs	0.2 µs	0.1 µs	0.3 µs	–
Reference marks I <sub>0</sub>	S2X, S2Y, S2W, S2Z and S2P: every 50 mm S2OX, S2OY, S2OW, S2OZ and S2OP: distance-coded I <sub>0</sub>				
Maximum cable length	50 m	50 m	50 m	50 m	150 m
Supply voltage	5 V ± 5%, < 150 mA (without load)	5 V ± 5%, < 150 mA (without load)	5 V ± 5%, < 150 mA (without load)	5 V ± 5%, < 150 mA (without load)	5 V ± 10%, < 150 mA (without load)
Accuracy	± 5 µm/m ± 3 µm/m				
Maximum vibration	100 m/s <sup>2</sup> (55 ... 2000 Hz) IEC 60068-2-6				
Maximum shock	300 m/s <sup>2</sup> (11 ms) IEC 60068-2-27				
Maximum acceleration	100 m/s <sup>2</sup> in the measuring direction				
Required moving force	< 4 N				
Operating temperature	0°C ... 50°C				
Storage temperature	-20°C ... 70°C				
Weight	0.25 kg + 2.25 kg/m				
Relative humidity	20 ... 80%				
Protection	IP 53 (standard) IP 64 (DIN 40050) using pressurized air at 0.8 ± 0.2 bar in linear encoders				
Reader head	With built-in connector				

(\*): contact Fagor Automation for higher speed.

# S2 model

Dimensions in mm

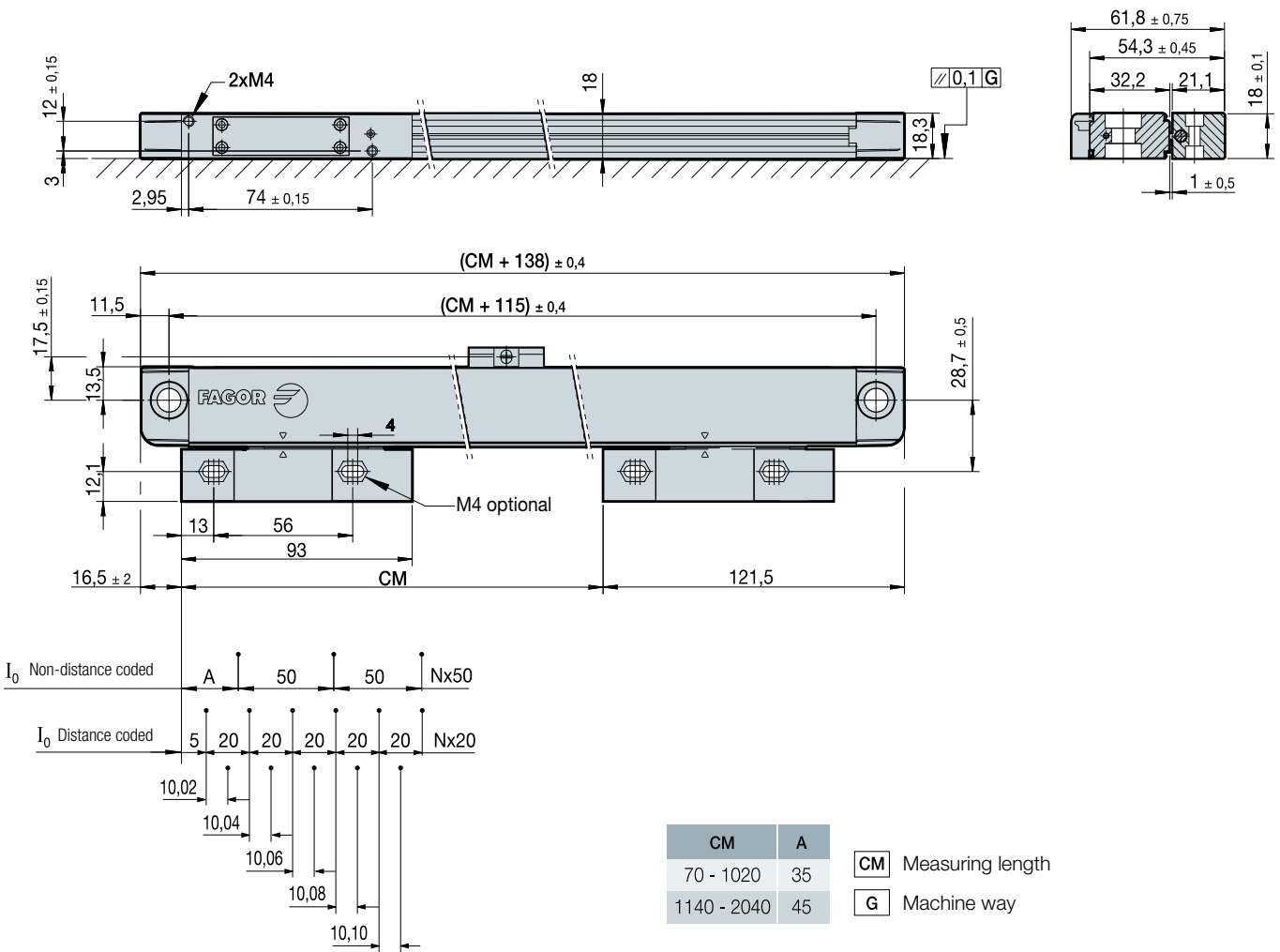

## Order identification

Example of Linear Encoder: **S20X-1140-5-A-T**

S2	0	X	1140	5	A	T
<b>Type of profile for reduced space:</b> • S2: Standard mounting for vibrations of up to 100 m/s <sup>2</sup>	<b>Type of reference mark I<sub>0</sub>:</b> • Blank space: Incremental, one mark every 50 mm • 0: Distance-coded marks	<b>Type of signal:</b> • X: 1 μm resolution differential TTL • Y: 0.5 μm resolution differential TTL • W: 0.1 μm resolution differential TTL • Z: 0.05 μm resolution differential TTL • P: 1 Vpp sinusoidal	<b>Measuring lengths in millimeters:</b> In the example (1140) = 1140 mm	<b>Accuracy of the linear encoder:</b> • 5: ± 5 μm • 3: ± 3 μm	<b>Air intake on the reader head:</b> • A: With air intake	<b>Threaded head:</b> • Blank space: No • T: M4

# SV2 series



Linear encoder with threaded head option for different installation options without the need for nuts. Small mounting support that may be secured from the top or from the bottom for easier installation.

Especially indicated for high standard environments in terms of speed and vibration.

Their special design of the securing points of the linear encoder (TDMS™), drastically reduces the errors and ensures the accuracy and repeatability of the encoders.

### Measuring lengths in millimeters

70 • 120 • 170 • 220 • 270 • 320 • 370 • 420 • 470 • 520 • 570 • 620  
 • 670 • 720 • 770 • 820 • 870 • 920 • 970 • 1 020 • 1 070 • 1 140  
 • 1 240 • 1 340 • 1 440 • 1 540 • 1 640 • 1 740 • 1 840 • 2 040

## Characteristics

	SV2X	SV2Y	SV2W	SV2Z	SV2P
Measurement	By means of a 20 µm-pitch graduated glass				
Glass thermal expansion coefficient	$\alpha_{\text{therm}}$ : 8 ppm/K aprox.				
Measuring resolution	1 µm	0.5 µm	0.1 µm	0.05 µm	Up to 0.1 µm
Output signals	□ □ TTL differential	□ □ TTL differential	□ □ TTL differential	□ □ TTL differential	~ 1 Vpp
Incremental signal period	4 µm	2 µm	0.4 µm	0.2 µm	20 µm
Limit frequency	500 KHz	1 MHz	1,5 MHz	500 KHz	100 KHz
Maximum speed	120 m/min	120 m/min	36 m/min	6 m/min (*)	120 m/min
Minimum distance between flanks	0.2 µs	0.2 µs	0.1 µs	0.3 µs	–
Reference marks I <sub>0</sub>	SV2X, SV2Y, SV2W, SV2Z and SV2P: every 50 mm SV2OX, SV2OY, SV2OW, SV2OZ and SV2OP: distance-coded I <sub>0</sub>				
Maximum cable length	50 m	50 m	50 m	50 m	150 m
Supply voltage	5 V ± 5%, < 150 mA (without load)	5 V ± 5%, < 150 mA (without load)	5 V ± 5%, < 150 mA (without load)	5 V ± 5%, < 150 mA (without load)	5 V ± 10%, < 150 mA (without load)
Accuracy	± 5 µm/m ± 3 µm/m				
Maximum vibration	200 m/s <sup>2</sup> (55 ... 2000 Hz) IEC 60068-2-6				
Maximum shock	300 m/s <sup>2</sup> (11 ms) IEC 60068-2-27				
Maximum acceleration	100 m/s <sup>2</sup> in the measuring direction				
Required moving force	< 4 N				
Operating temperature	0°C ... 50°C				
Storage temperature	-20°C ... 70°C				
Weight	0.25 kg + 2.25 kg/m				
Relative humidity	20 ... 80%				
Protection	IP 53 (standard) IP 64 (DIN 40050) using pressurized air at 0.8 ± 0.2 bar in linear encoders				
Reader head	With built-in connector				

(\*): contact Fagor Automation for higher speed.

# SV2 model

Dimensions in mm

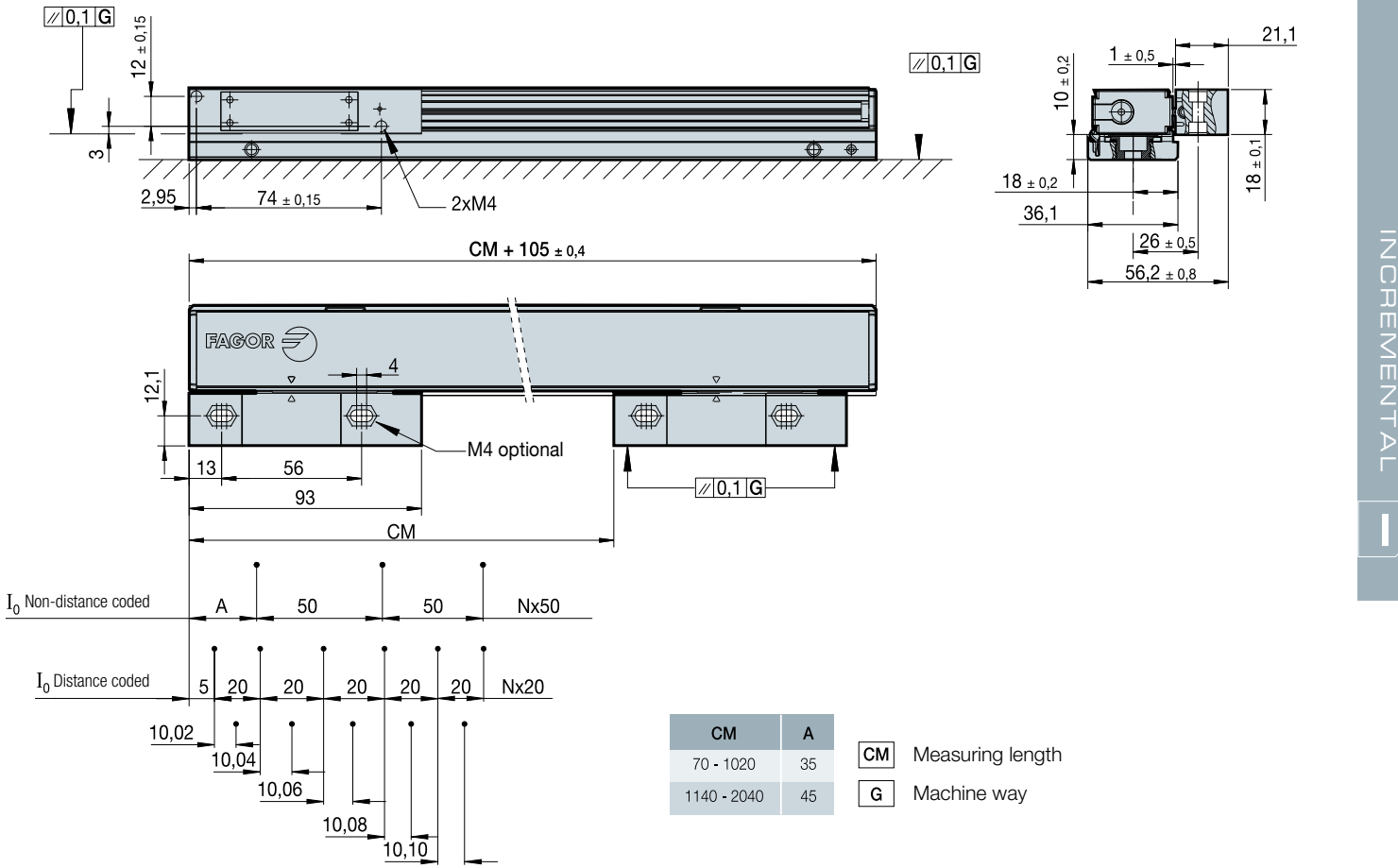

CM	70	120	170	220	270	320	370	420	470	520	570	620	670	720	770
M	37.5	55	75	100	115	140	175	200	225	250	275	300	325	350	375
CM	820	870	920	970	1020	1070	1140	1240	1340	1440	1540	1640	1740	1840	2040
M	400	425	450	475	500	515	555	610	655	710	760	810	855	910	1010

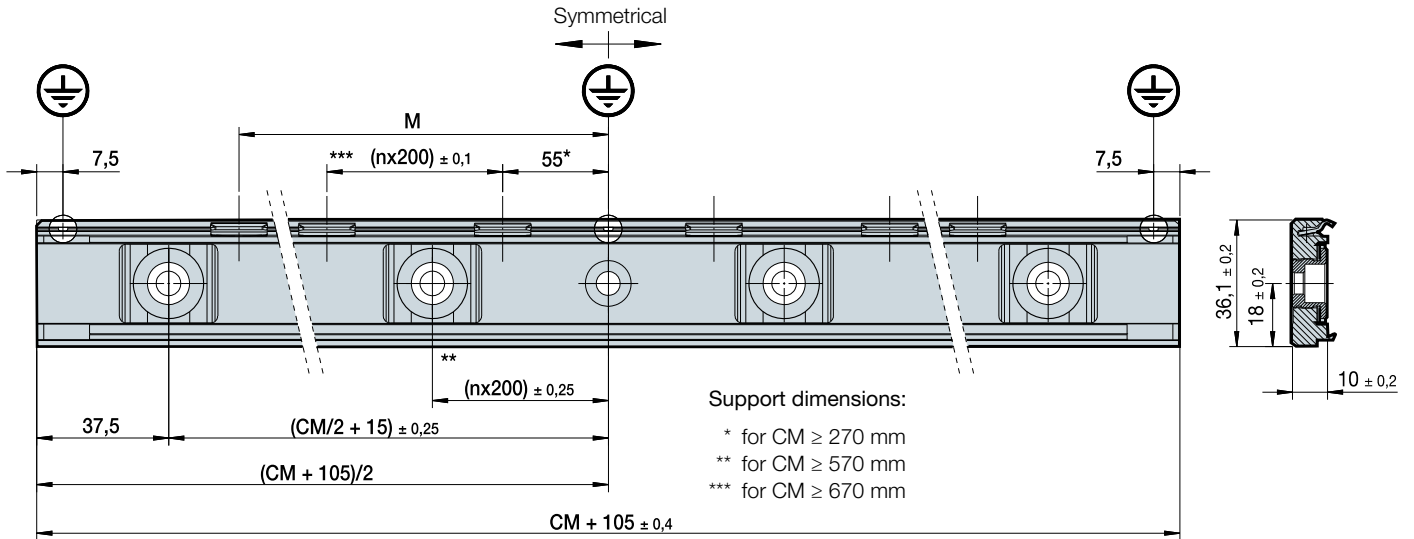

## Order identification

Example of Linear Encoder: SV2OX-1140-5-B-A-T

SV2	O	X	1140	5	B	A	T
<b>Type of profile for reduced spaces:</b> • SV2: Vibration mounting for up to 200 m/s <sup>2</sup>	<b>Type of reference mark I<sub>0</sub>:</b> • Blank space: Incremental, one mark every 50 mm • O: Distance-coded marks	<b>Type of signal:</b> • X: 1 µm resolution differential TTL • Y: 0.5 µm resolution differential TTL • W: 0.1 µm resolution differential TTL • Z: 0.05 µm resolution differential TTL • P: 1 Vpp sinusoidal	<b>Measuring lengths in millimeters:</b> In the example (1140) = 1140 mm	<b>Precisión del encoder lineal:</b> • 5: ± 5 µm • 3: ± 3 µm	<b>Linear encoder with mounting support:</b> • B: With mounting support for vibrations of up to 200 m/s <sup>2</sup>	<b>Air intake on the reader head:</b> • A: With air intake	<b>Threaded head:</b> • Blank space: No • T: M4

# direct connection cables

## Connection to FAGOR CNC

### UP TO 12 METERS

#### EC...P-D

Lengths: 1, 3, 6, 9 and 12 meters

SUB D 15 HD connector (male Pin )

Pin	Signal	Color
1	A	Green
2	/A	Yellow
3	B	Blue
4	/B	Red
5	I <sub>0</sub>	Grey
6	/I <sub>0</sub>	Pink
9	+5 V	Brown
11	0 V	White
15	Ground	Shield
Housing	Ground	Shield

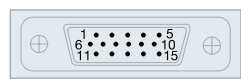

### FROM 12 METERS ON

EC...A-C1 cable + XC-C2... D extension cable

#### EC...A-C1 / EC...A-C5

Lengths: 1 and 3 meters

12 CIRCULAR connector (male Pin )

Pin	Signal	Color
5	A	Green
6	/A	Yellow
8	B	Blue
1	/B	Red
3	I <sub>0</sub>	Grey
4	/I <sub>0</sub>	Pink
7	/Alarm	Purple
12	+5 V	Brown
2	+5 V sensor	
10	0 V	White
11	0 V sensor	
Housing	Ground	Shield

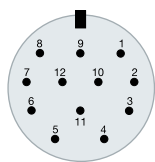

#### XC-C2...D extension cable

Lengths: 5, 10, 15, 20 and 25 meters

12 CIRCULAR connector (female Pin )

SUB D 15 HD connector (male Pin )

Pin	Pin	Signal	Color
5	1	A	Brown
6	2	/A	Green
8	3	B	Grey
1	4	/B	Pink
3	5	I <sub>0</sub>	Red
4	6	/I <sub>0</sub>	Black
7	8	/Alarm	Purple
12	9	5 V	Brown/ Green
2	9	+5 V sensor	Blue
10	11	0 V	White/ Green
11	11	0 V sensor	White
Housing	Housing	Ground	Shield

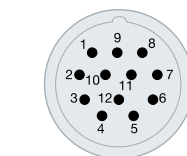

# Connection to other CNC's

## UP TO 12 METERS

For direct connection to FANUC® (second feedback)

### EC-...C-FN 1

Lengths: 1, 3, 6, 9 and 12 meters

HONDA / HIROSE connector (female Pin )

 Pin	Signal	Color
1	A	Green
2	/A	Yellow
3	B	Blue
4	/B	Red
5	I <sub>0</sub>	Grey
6	/I <sub>0</sub>	Pink
9	+5 V	Brown
18-20	+5 V sensor	
12	0 V	White
14	0 V sensor	
16	Ground	Internal shield
Housing	Ground	External shield

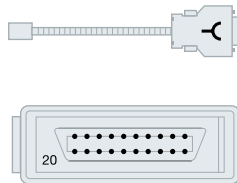

For direct connection to SIEMENS® (Solution Line)

SME20 (1 Vpp only)

### EC...A-C5

SMC20 (1 Vpp only)

### EC...P-S3

Lengths: 1, 3, 6, 9 and 12 meters

SUB D25 connector (female Pin )

 Pin	Signal	Color
3	A	Green
4	/A	Yellow
6	B	Blue
7	/B	Red
17	I <sub>0</sub>	Grey
18	/I <sub>0</sub>	Pink
1	+5 V	Brown
14	+5 V sensor	
2	0 V	White
16	0 V sensor	
Housing	Ground	Shield

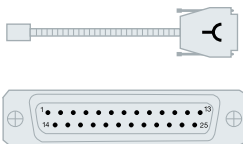

SMC30 (differential TTL only)

### EC...P-S2

Lengths: 1, 3, 6, 9 and 12 meters

SUB D 15 connector (male Pin )

 Pin	Signal	Color
15	A	Green
14	/A	Yellow
13	B	Blue
12	/B	Red
10	I <sub>0</sub>	Grey
11	/I <sub>0</sub>	Pink
4	+5 V	Brown
5	+5 V	
7	0 V	White
Housing	Ground	Shield

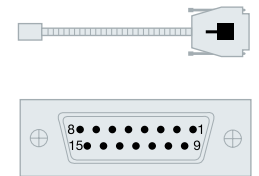

Without a connector at one end; for other applications.

### EC...AS-O

Lengths: 1, 3, 6, 9 and 12 meters

Signal	Color
A	Green
/A	Yellow
B	Blue
/B	Red
I <sub>0</sub>	Grey
/I <sub>0</sub>	Pink
+5 V	Brown
+5 V sensor	Purple
0 V	White
0 V sensor	Black
Ground	Shield



# direct connection cables



## Connection to other CNC's

### FROM 12 METERS ON

- EC-...A-C1 cable + XC-C2... FN1 extension cable
- EC-...A-C5 cable + XC-C4...C5 extension cable (1 Vpp only)
- EC-...A-C5 cable + XC-C4...S3 extension cable (1 Vpp only)
- EC-...A-C5 cable + XC-C4...S2 extension cable (differential TTL only)

### XC-C2... FN1 extension cable

Lengths: 5, 10, 15, 20 and 25 meters

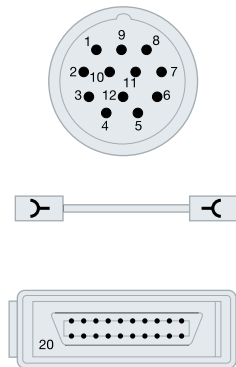

12 CIRCULAR connector (female Pin )  
HONDA / HIROSE connector (female Pin )

 Pin	 Pin	Signal	Color
5	1	A	Brown
6	2	/A	Green
8	3	B	Grey
1	4	/B	Pink
3	5	I <sub>0</sub>	Red
4	6	/I <sub>0</sub>	Black
12	9	+5 V	Brown/ Green
2	18-20	+5 V sensor	Blue
10	12	GND	White/ Green
11	14	GND sensor	White
Housing	16	Ground	Shield



### XC-C4-... C5 extension cable

Lengths: 5, 10, 15, 20 and 25 meters

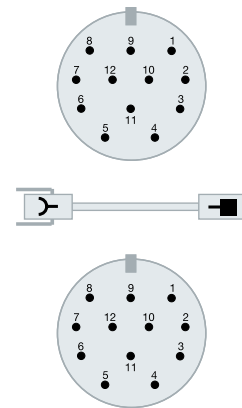

12 CIRCULAR connector (female Pin )  
12 CIRCULAR connector (male Pin )

 Pin	 Pin	Signal	Color
5	5	A	Brown
6	6	/A	Green
8	8	B	Grey
1	1	/B	Pink
3	3	I <sub>0</sub>	Red
4	4	/I <sub>0</sub>	Black
12	12	+5 V	Brown/ Green
2	2	+5 V sensor	Blue
10	10	0 V	White/ Green
11	11	0 V sensor	White
7	7	/Alarm	Purple
Housing	Housing	Ground	Shield



### XC-C4-... S3 extension cable

Lengths: 5, 10, 15, 20 and 25 meters



12 CIRCULAR connector (female Pin )  
SUB D25 connector (female Pin )

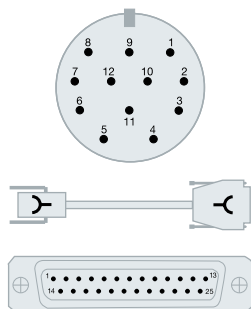

 Pin	 Pin	Signal	Color
5	3	A	Brown
6	4	/A	Green
8	6	B	Grey
1	7	/B	Pink
3	17	I <sub>0</sub>	Red
4	18	/I <sub>0</sub>	Black
12	1	+5 V	Brown/ Green
2	14	+5 V sensor	Blue
10	2	0 V	White/ Green
11	16	0 V sensor	White
Housing	Housing	Ground	Shield



### XC-C4-... S2 extension cable

Lengths: 5, 10, 15, 20 and 25 meters

12 CIRCULAR connector (female Pin )  
SUB D15 connector (male Pin )

 Pin	 Pin	Signal	Color
5	15	A	Brown
6	14	/A	Green
8	13	B	Grey
1	12	/B	Pink
3	10	I <sub>0</sub>	Red
4	11	/I <sub>0</sub>	Black
12	4	+5 V	Brown/ Green
2	5	+5 V	
2	6	+5 V sensor	Blue
10	7	0 V	White/ Green
11	9	0 V sensor	White
Housing	Housing	Ground	Shield

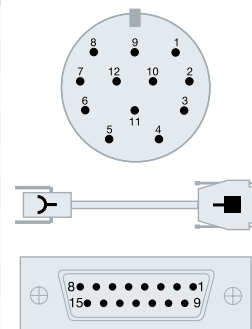





# accessories

## Protection

Enclosed **linear encoders** meet the protection requirements IP 53 of the **IEC 60 529** standard when mounted so water splashes don't hit the sealing lips directly. For further protection, a separate protection guard must be mounted.

- **AI-400 filter**

The air coming from an compressed air supply must be treated and filtered in the AI-400 unit which consists of:

- Filtering and pressure regulating group.
- Fast inlets and joints for 4 measuring systems.
- A plastic tube 25 m long with an inside diameter of 4 mm and outside diameter of 6 mm.

- **AI-500 filter**

Under extreme conditions where the air must be dried, Fagor Automation recommends using their air filter AI-500. This includes a drying module that makes it possible to reach the conditions required by Fagor Automation feedback systems.

If the encoder is exposed to concentrated liquids and vapor, compressed air may be used to achieve a protection degree of IP 64 and prevent any contamination from getting inside. For these cases, Fagor Automation recommends their Air filter units AI-400 and AI-500.



AI-500 filter MODELS	
For 2 axes:	AI-525
For 4 axes:	AI-550
For 6 axes:	AI-590

Technical Characteristics	Filters AI-400 / AI-500	
	Standard	Special
Maximum input pressure	10.5 bar	14 bar
Maximum operating temperature	52°C	80°C
Output pressure of the unit	1 bar	
Consumption per measuring system	10 l/min.	
Safety	Micro-filter saturation alarm	

### Air conditions (Meets the standard DIN ISO 8573-1)

Fagor Automation linear feedback systems require the following air conditions:

- Class 1 - Maximum particle 0.12 μ
- Class 4 (7 bars) - Dew point 3°C
- Class 1 - Maximum oil concentration: 0.01 mg/m<sup>3</sup>.

### Safety switch

It consists of a pressostat capable of activating an alarm switch when the pressure gets below 0.66 bar.

### Technical data:

The switching pressure may be adjusted between 0.3 and 1.5 bar.

- Load: 4 A.
- Voltage: 250 V approx.
- Protection: IP65.



FeeDat® is a registered trademark of Fagor Automation,  
DRIVE-CLIQ® is a registered trademark of SIEMENS® Aktiengesellschaft,  
SIEMENS® is a registered trademark of SIEMENS® Aktiengesellschaft,  
FANUC® is a registered trademark of FANUC® Ltd.  
MITSUBISHI® is a registered trademark of MITSUBISHI® Shoji Kaisha, Ltd.  
PANASONIC® is a registered trademark of PANASONIC® Corporation and  
BiSS® is a registered trademark of IC-Hauss GmbH.



FAGOR AUTOMATION

**Fagor Automation, S. Coop.**  
 Bº San Andrés, 19  
 E-20500 Arrasate - Mondragón  
 SPAIN  
 Tel.: +34 943 039 800  
 Fax: +34 943 791 712  
 E-mail: info@fagorautomation.es



Fagor Automation holds the ISO 9001  
 Quality System Certificate and the  
 CE Certificate for all products manufactured.

[www.fagorautomation.com](http://www.fagorautomation.com)



worldwide automation